

THERMAL PRINTER TSP650 SERIES

Hardware Manual

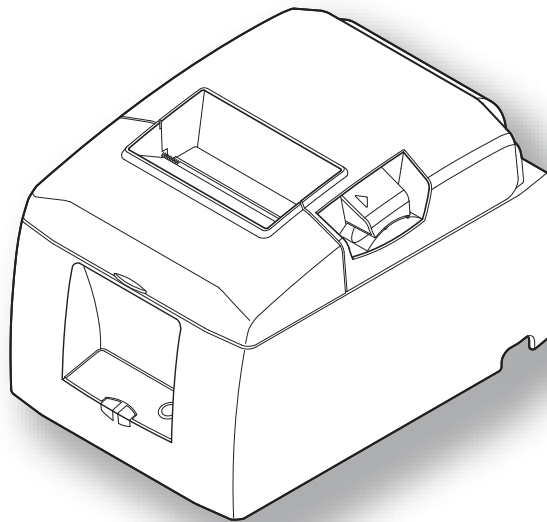

star 

**Federal Communications Commission
Radio Frequency Interference
Statement**

This device complies with Part 15 of the FCC Rules. Operation is subject to the following two conditions: (1) This device may not cause harmful interference, and (2) this device must accept any interference received, including interference that may cause undesired operation.

NOTE: This equipment has been tested and found to comply with the limits for a Class A digital device, pursuant to Part 15 of the FCC Rules. These limits are designed to provide reasonable protection against harmful interference when the equipment is operated in a commercial environment. This equipment generates, uses and can radiate radio frequency energy and, if not installed and used in accordance with the instruction manual, may cause harmful interference to radio communications. Operation of this equipment in a residential area is likely to cause harmful interference in which case the user will be required to correct the interference at his own expense.

This statement will be applied only for the printers marketed in U.S.A.

FCC WARNING

Changes or modifications not expressly approved by the party responsible for compliance could void the user's authority to operate the equipment.

For compliance with the Federal Noise Interference Standard, this equipment requires a shielded cable.

For RF interference suppression, if a ferrite core is provided with this device, affix it to the interface cable

**Statement of
The Canadian Department of Communications
Radio Interference Regulationst**

This Class A digital apparatus complies with Canadian ICES-003.

Cet appareil numérique de la classe A est conforme à la norme NMB-003 du Canada.

The above statement applies only to printers marketed in Canada.

Trademark acknowledgments

TSP650: Star Micronics Co., Ltd.

Notice

- All rights reserved. Reproduction of any part of this manual in any form whatsoever, without STAR's express permission is forbidden.
- The contents of this manual are subject to change without notice.
- All efforts have been made to ensure the accuracy of the contents of this manual at the time of going to press. However, should any errors be detected, STAR would greatly appreciate being informed of them.
- The above notwithstanding, STAR can assume no responsibility for any errors in this manual.

TABLE OF CONTENTS

1. Unpacking and Installation	1
1-1. Unpacking	1
1-2. Choosing a place for the printer	2
2. Parts Identification and Nomenclature	3
2-1. Cutter Model	3
2-2. Tear Bar Model	3
3. Setup	4
3-1. Connecting the Cable to the PC	4
3-2. Connecting the Cable to the Printer	5
3-3. Installing the Printer Software	8
3-4. Connecting the Optional AC Adapter	9
3-5. Turning Power On.....	10
3-6. Connecting to a Peripheral Unit.....	11
3-7. Loading the Paper Roll	12
4. Attaching the Accessories	16
4-1. Attaching the Holder Plate.....	16
4-2. Attaching the Rubber Feet	17
4-3. Switch Cover Installation.....	18
5. Consumable Parts and AC Adapter	19
5-1. Thermal Paper Roll	19
5-2. AC adapter (option)	20
6. Control Panel and Other Functions	21
6-1. Control Panel	21
6-2. Errors.....	21
6-3. Self-Printing.....	23
7. Adjusting the Near-end Sensor	24
8. Preventing and Clearing Paper Jams	26
8-1. Preventing Paper Jams	26
8-2. Removing Paper Jam	26
8-3. Releasing a Locked Cutter (Auto Cutter Mode only).....	27
9. Periodical Cleaning	28
9-1. Cleaning the Thermal Head	28
9-2. Cleaning the Rubber Roller	28
9-3. Cleaning the Paper Holder and the Surrounding Area	28
10. Specifications	29
10-1. General Specifications.....	29
10-2. Auto Cutter Specifications	30
10-3. Interface	30
10-4. Electrical Characteristics (AC adapter).....	30
10-5. Environmental Requirements.....	31
10-6. Reliability Specifications	32
11. Dip Switch Setting	33
11-1. Parallel Interface Model.....	34
11-2. RS-232C Interface Model	36
11-3. USB Interface Model	39
11-4. EthernetInterface Model	41

12. Parallel Interface	44
13. RS-232C Serial Interface	45
13-1. Interface Specifications	45
13-2. RS-232C Connector	46
13-3. Cable Connections	48
14. USB and Ethernet Interface	49
15. Peripheral Unit Drive Circuit	50
16. Memory Switch Settings	52
17. Release History	53

Please access the following URL

<http://www.star-m.jp/eng/dl/dl02.htm>
for the latest revision of the manual.

1. Unpacking and Installation

1-1. Unpacking

After unpacking the unit, check that all the necessary accessories are included in the package.

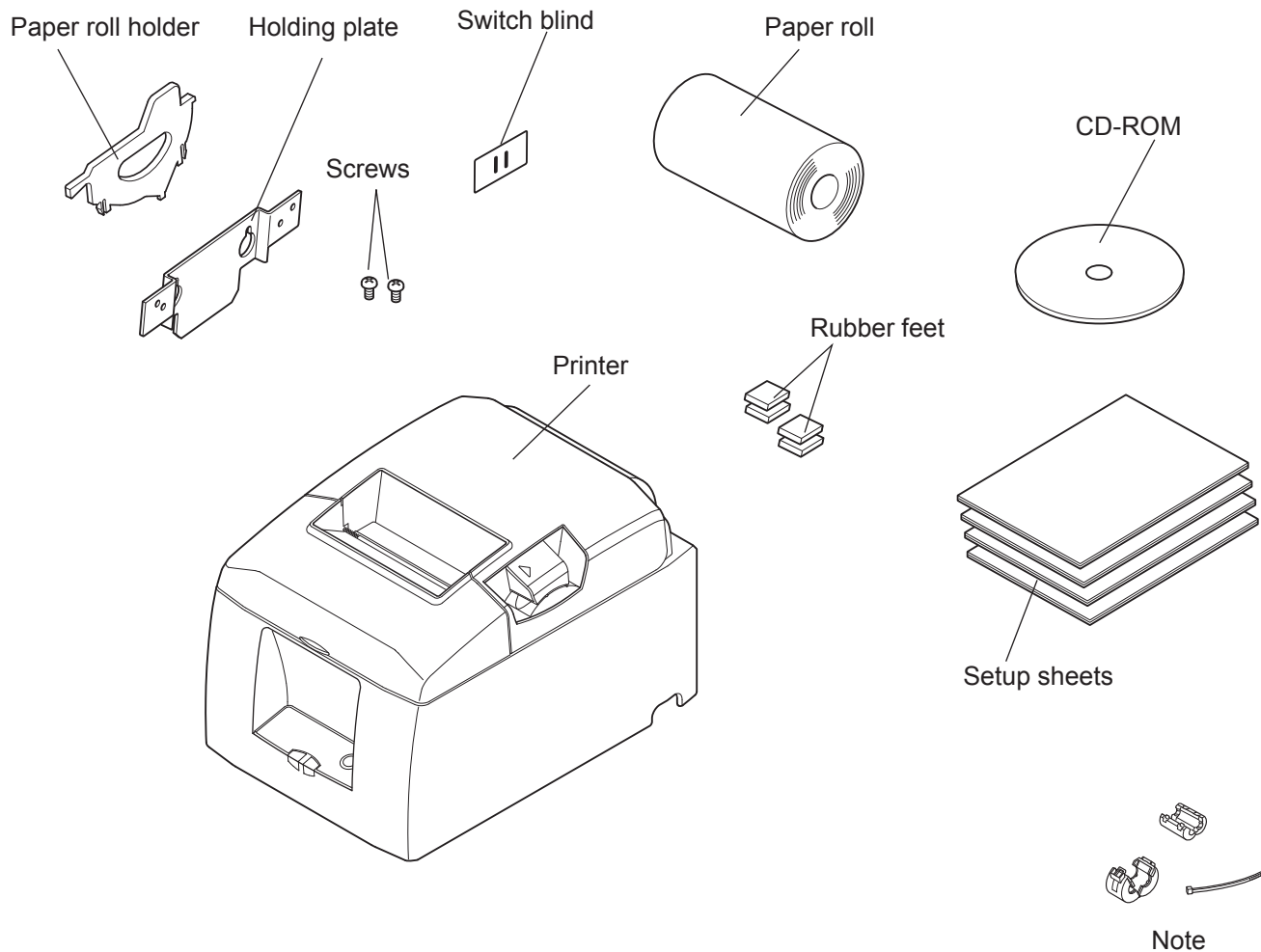

Note: The ferrite core and fastener provided with your printer depend on your printer configuration.

Fig. 1-1 Unpacking

If anything is missing, contact the dealer where you bought the printer and ask them to supply the missing part. Note that it is a good idea to keep the original box and all the packing materials just in case you need to pack the printer up again and send it somewhere at a later date.

1-2. Choosing a place for the printer

Before actually unpacking the printer, you should take a few minutes to think about where you plan to use it. Remember the following points when doing this.

- ✓ Choose a firm, level surface where the printer will not be exposed to vibration.
- ✓ The power outlet you plan to connect to for power should be nearby and unobstructed.
- ✓ Make sure that the printer is close enough to your host computer for you to connect the two.
- ✓ Make sure that the printer is not exposed to direct sunlight.
- ✓ Make sure that the printer is well away from heaters and other sources of extreme heat.
- ✓ Make sure that the surrounding area is clean, dry, and free of dust.
- ✓ Make sure that the printer is connected to a reliable power outlet. It should not be on the same electric circuit as copiers, refrigerators, or other appliances that cause power spikes.
- ✓ Make sure that the room where you are using the printer is not too humid.
- ✓ This device employs a DC motor and switches that have an electrical contact point. Avoid using the device in environments where silicon gas can become volatile.
- ✓ When disposing of the printer, obey local regulations.

WARNING

- ✓ Shut down your equipment immediately if it produces smoke, a strange odor, or unusual noise. Immediately unplug the equipment and contact your dealer for advice.
- ✓ Never attempt to repair this product yourself. Improper repair work can be dangerous.
- ✓ Never disassemble or modify this product. Tampering with this product may result in injury, fire, or electric shock.

2. Parts Identification and Nomenclature

2-1. Cutter Model

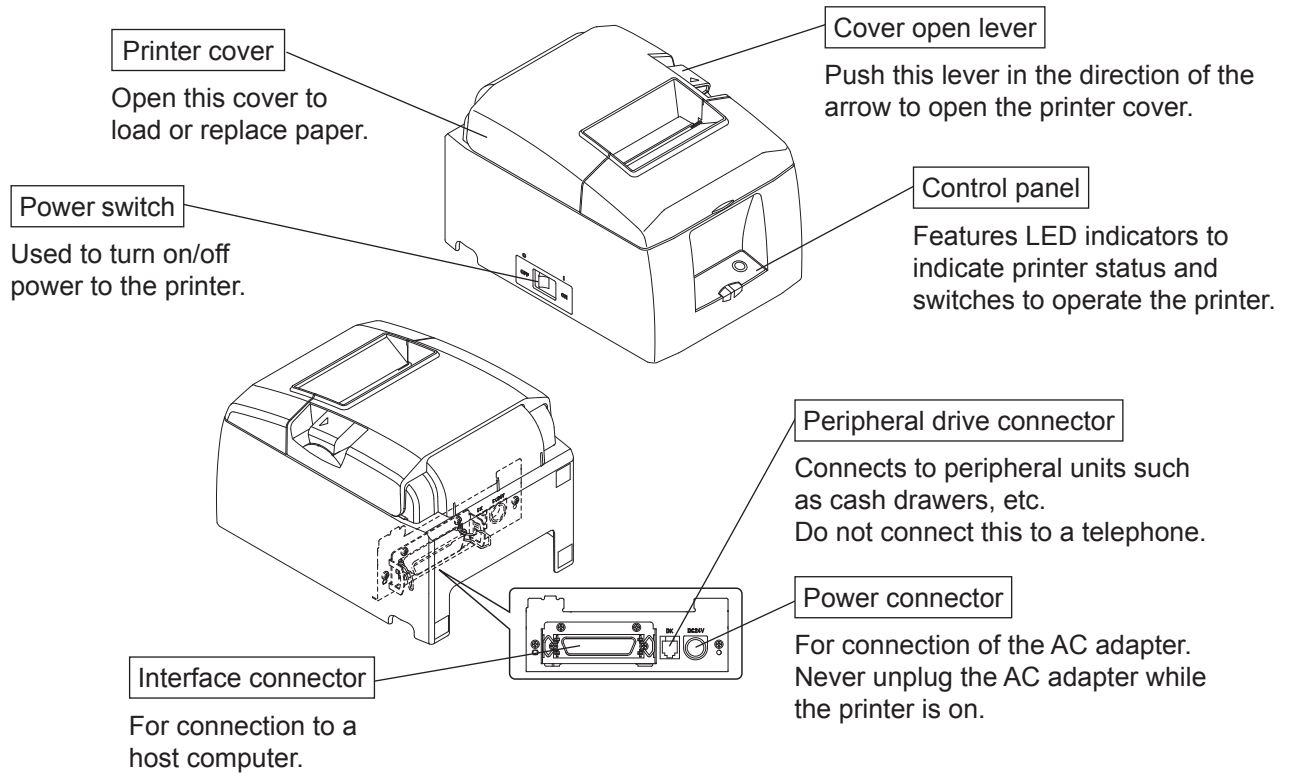

2-2. Tear Bar Model

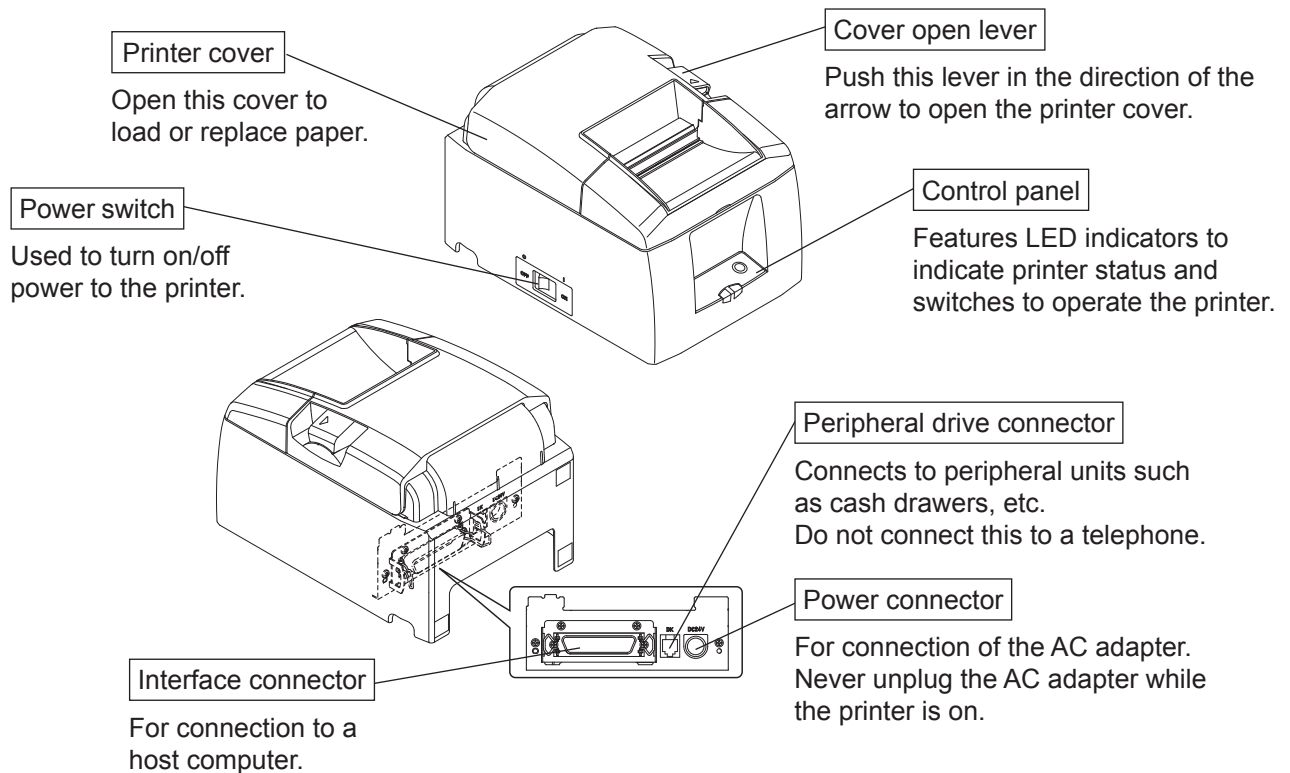

3. Setup

3-1. Connecting the Cable to the PC

3-1-1. Parallel Interface Cable

Connect the parallel interface cable to a parallel port of your PC.

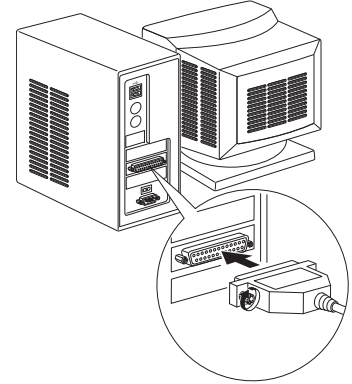

3-1-2. RS-232C Interface Cable

Connect the RS-232C interface cable to a RS-232C port of your PC.

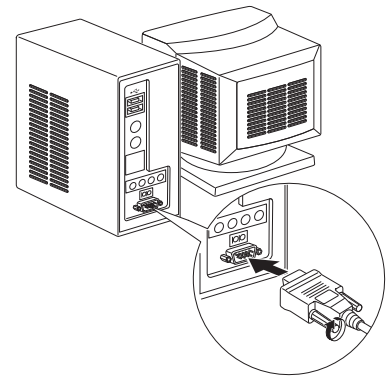

3-1-3. USB Interface Cable

Connect the USB interface cable to a USB port of your PC.

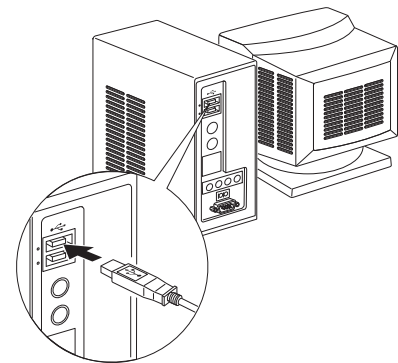

3-1-4. Ethernet Interface cable

Connect the ethernet interface cable to a ethernet port of your PC.

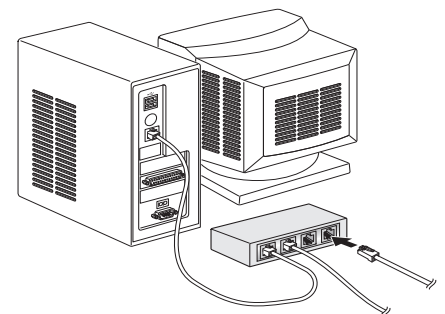

3-2. Connecting the Cable to the Printer

Note that the interface cable is not provided. Please use a cable that meets specifications.

⚠ CAUTION

Before connecting/disconnecting the interface cable, make sure that power to the printer and all the devices connected to the printer is turned off. Also make sure the power cable plug is disconnected from the AC outlet.

3-2-1. Parallel Interface Cable

- (1) Make sure the printer is turn off.
- (2) Affix the ferrite core onto the cable as shown in the illustration.
- (3) Pass the fastener through the ferrite core.
- (4) Loop the fastener around the cable and lock it.
Use scissors to cut off any excess.

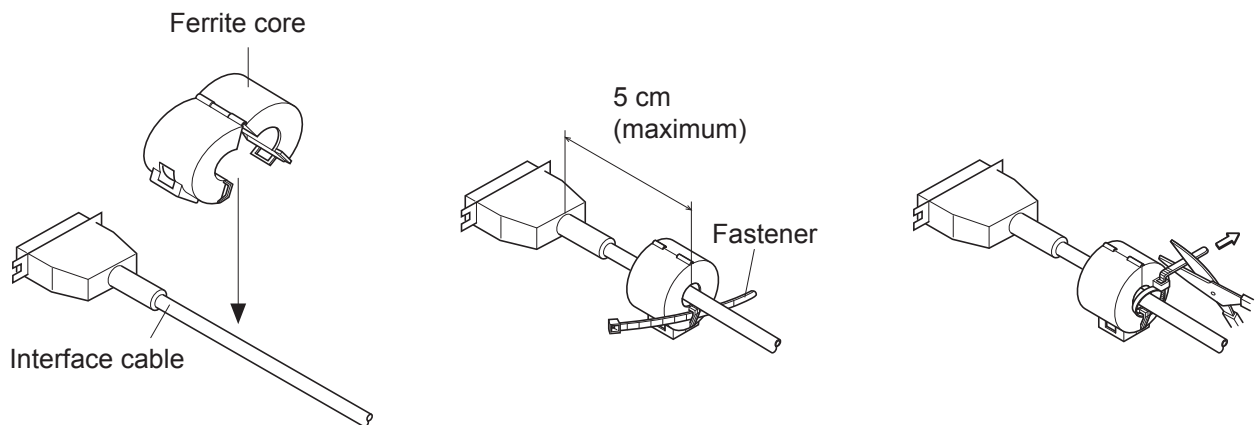
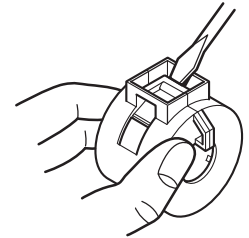

- (5) Connect the interface cable to the connector on the rear panel of the printer.
- (6) Fasten the connector clasps.

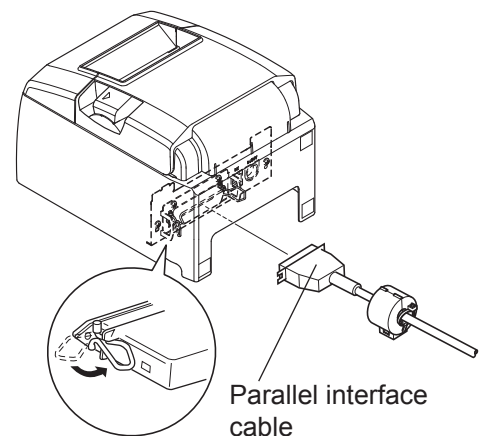

3-2-2. RS-232C Interface Cable

- (1) Make sure the printer is turn off.

⚠ CAUTION

Before connecting/disconnecting the interface cable, make sure that power to the printer and all the devices connected to the printer is turned off. Also make sure the power cable plug is disconnected from the AC outlet.

- (2) Connect the interface cable to the connector on the rear panel of the printer.
- (3) Tighten the connector screws.

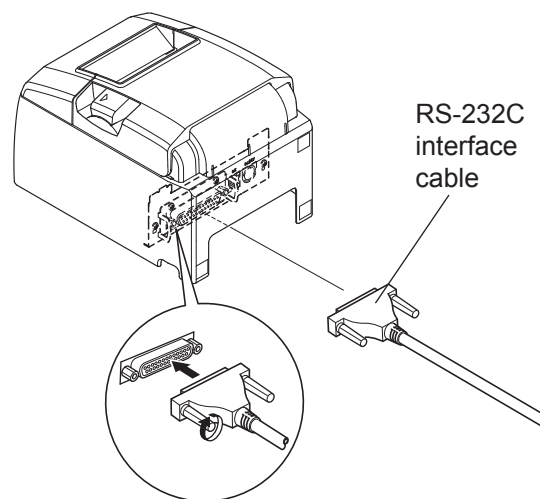

3-2-3. USB Interface Cable

Affix the ferrite core onto the USB cable as shown in the illustration below and make sure to pass the cable through the cable support as shown in the illustration.

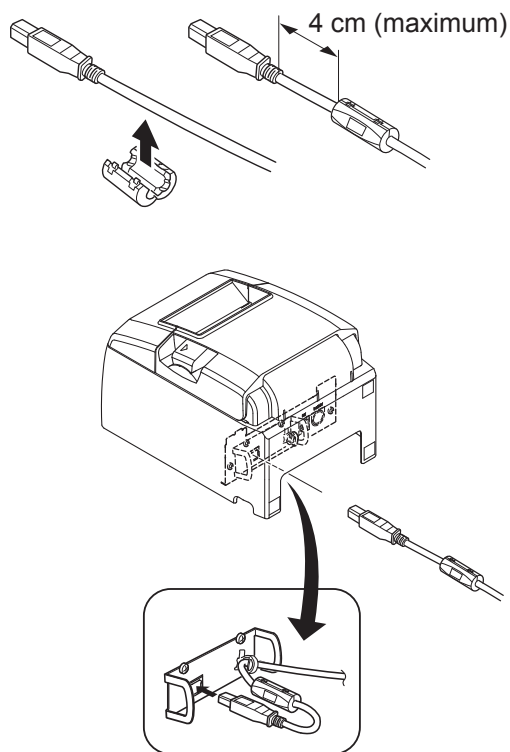

3-2-4. Connecting Ethernet Cable

If a ferrite core is included, install the ferrite core onto the Ethernet cable according to the following procedure to prevent electrical noise.

If a ferrite core is not included, perform steps (1) and (5) only.

When using an Ethernet cable that is 10 m or less, shielded cable is recommended.

- (1) Make sure the printer is turned off.
- (2) Install the ferrite core onto the ethernet cable as shown in the illustration below.
- (3) Pass the fastener through the ferrite core.
- (4) Loop the fastener around the cable and lock it. Use scissors to cut off any excess.

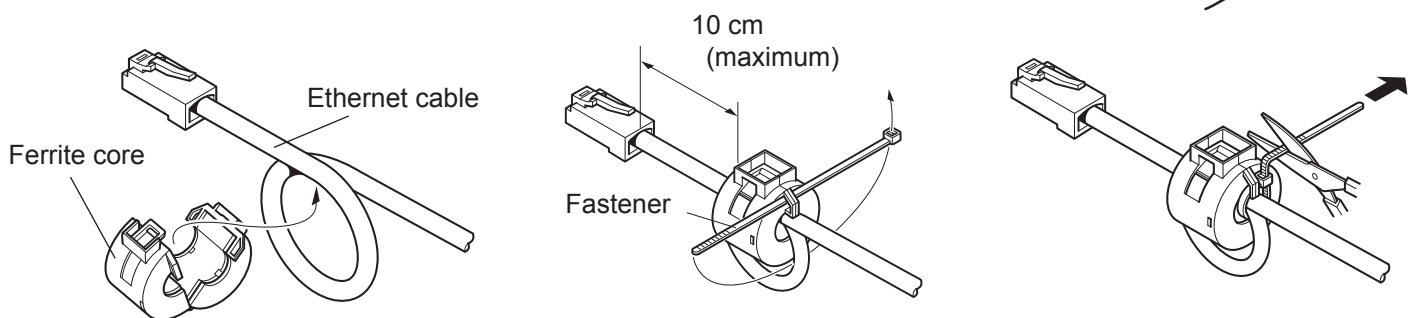

- (5) Connect the interface cable to the connector on the rear panel of the printer.

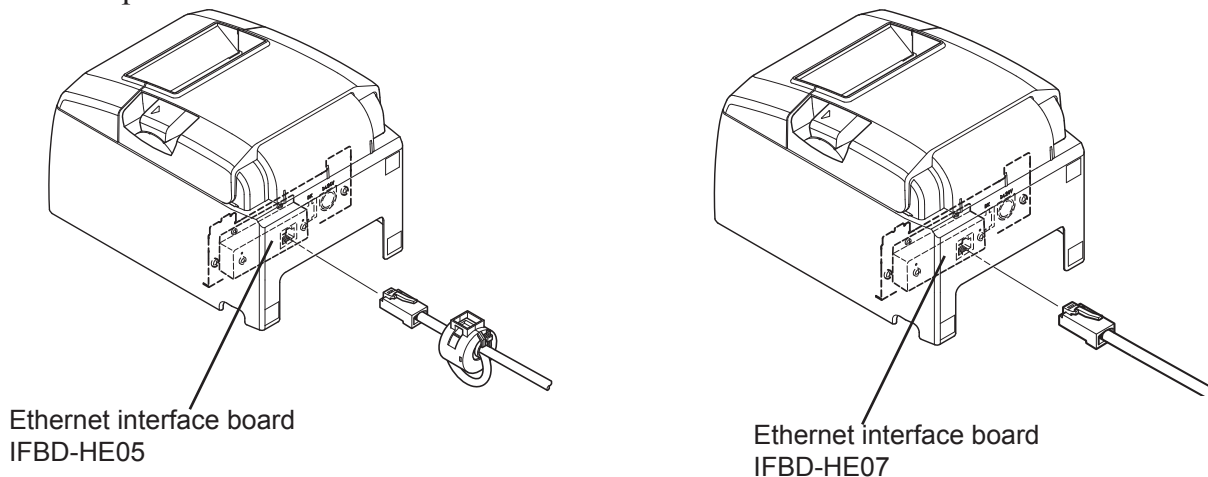

Link disconnection detection feature

The Ethernet interface model is equipped with a link disconnection detection feature. If the printer is turned on when an Ethernet cable is not connected to it, the POWER and ERROR lamps are simultaneously turned on and off at 2-second intervals to indicate the disconnection.

Be sure to connect the Ethernet cable from a PC or hub to the printer, and then turn the printer on.

3-3. Installing the Printer Software

Here is the procedure for installing the printer driver and utility software, which are stored on the supplied CD-ROM.

The procedure applies to the Windows operating systems shown below.

- Windows XP (SP2 or later)
- Windows Vista
- Windows 7

- (1) Turn ON the power to your PC to start Windows.
- (2) Insert the supplied CD-ROM (Drivers and Utilities) into the CD-ROM drive.
- (3) Follow the instructions that appear on the screen.
- (4) The dialog shown in the illustration indicates that the procedure has been completed. Click “Finish”.

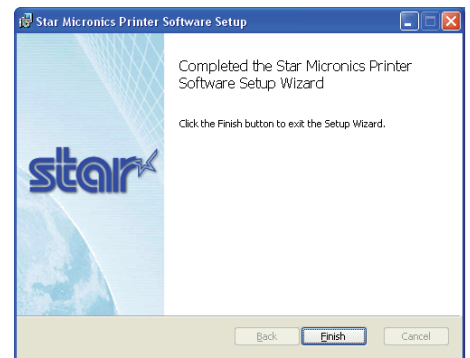
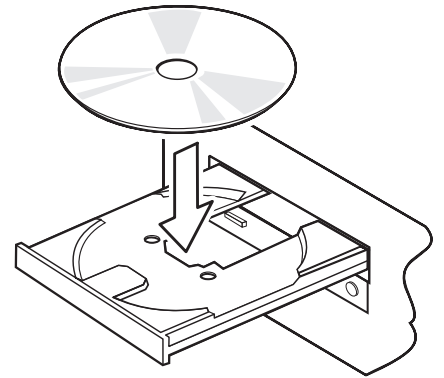

The dialog that appears on the screen varies with your system. This completes the installation of the printer software. A message will appear, prompting you to restart. Restart Windows.

3-4. Connecting the Optional AC Adapter

Note: Before connecting/disconnecting the AC adapter, make sure that power to the printer and all the devices connected to the printer is turned off. Also make sure the power cable plug is disconnected from the AC outlet.

(1) Connect the AC adapter to the power cable.

Note: Use only the standard AC adapter and power cable.

(2) Connect AC adapter to the connector on the printer.

(3) Insert the power cable plug into an AC outlet.

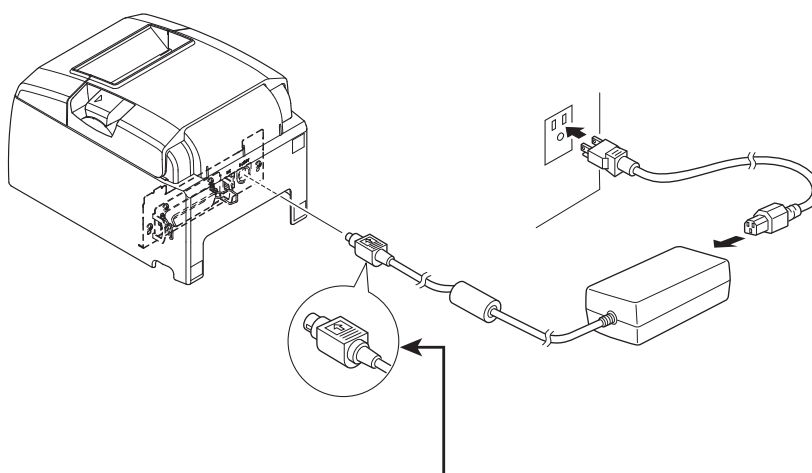

⚠ CAUTION

When disconnecting the cable, take hold of the cable connector to pull it out. Releasing the lock makes it easy to disconnect the connector. Pulling the cable excessively could cause damage to the connector.

3-5. Turning Power On

Make sure that the Power cord has been connected as described in 3-4.

Turn ON the power switch located on the front of the printer.
The POWER lamp on the control panel will light up.

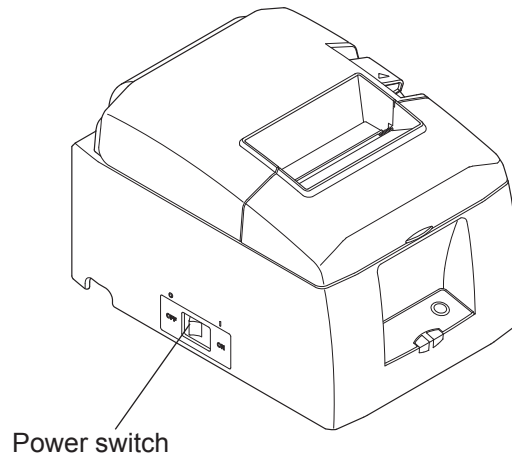

⚠ CAUTION

We recommend that you unplug the printer from the power outlet whenever you do not plan to use it for long periods. Because of this, you should locate the printer so that the power outlet it is plugged into is nearby and easy to access.

When an Switch blind is affixed to the printer above the power switch, the ON/OFF marks of the power switch may be hidden. If this occurs, remove the power cord from the outlet to turn the printer OFF.

3-6. Connecting to a Peripheral Unit

You can connect a peripheral unit to the printer using a modular plug. See “Modular plug” on page 50 for details about the type of modular plug that is required. Note that this printer does not come with a modular plug or wire, so it is up to you to obtain one that suits your needs.

⚠ CAUTION

Make sure that the printer is turned off and unplugged from the AC outlet and that the computer is turned off before making connections.

Connect the peripheral drive cable to the connector on the rear panel of the printer.

⚠ CAUTION

Do not connect a telephone line into the peripheral drive connector. Failure to observe this may result in damage to the printer.

Also, for safety purposes, do not connect wiring to the external drive connector if there is a chance it may carry peripheral voltage.

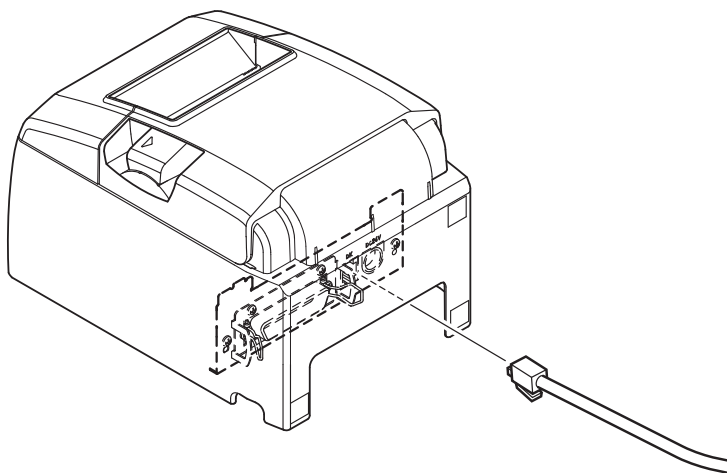

3-7. Loading the Paper Roll

3-7-1. Using 79.5 mm Width Paper Roll

Be sure to use roll paper that matches the printer's specification.

When using a paper roll with an 57.5 mm width, install the paper roll holder as described on the following page.

- 1) Push the cover open lever, and open the printer cover.
- 2) While observing the direction of the roll, set the paper roll into the hollow, and pull on the leading edge of the paper toward you.

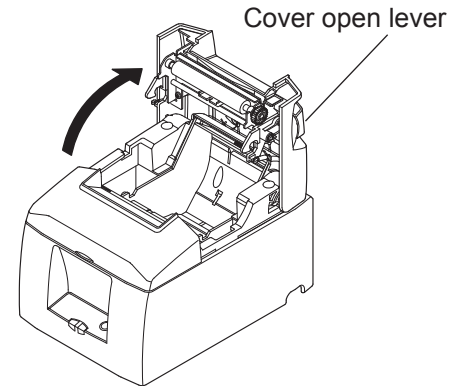

⚠ CAUTION

Do not pull out the end of the paper diagonally, as it will cause the paper to become jammed or skewed.

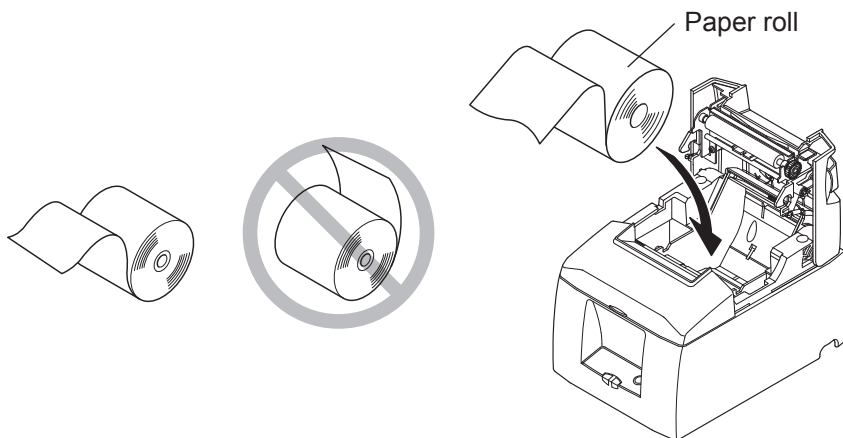

- 3) Push down both sides of the printer cover to close.

Note: Make sure that the printer cover is securely closed.

- 4) **Tear Bar Model:**
Tear off the paper as shown.

Auto Cutter Model:

If the printer cover is closed after turning on the power, the cutter operates automatically and the front end of the paper is cut.

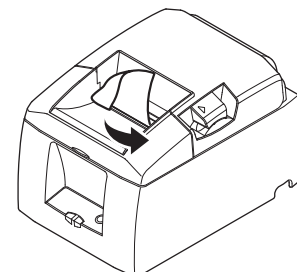
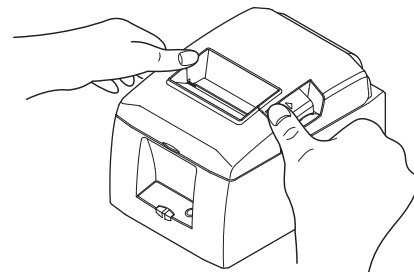

Tear Bar Model

3-7-2. Using 57.5 mm Width Paper Roll

When using a paper roll with 57.5 mm width, install the supplied paper guide on the printer. To change the effective print width (roll paper width), change the setting at memory switch configuration Utility. For details on the setting of the memory switches, refer to the software manual located in the “Documents” folders on the CD-ROM.

- ① Insert the paper guide along the groove in the unit as shown.

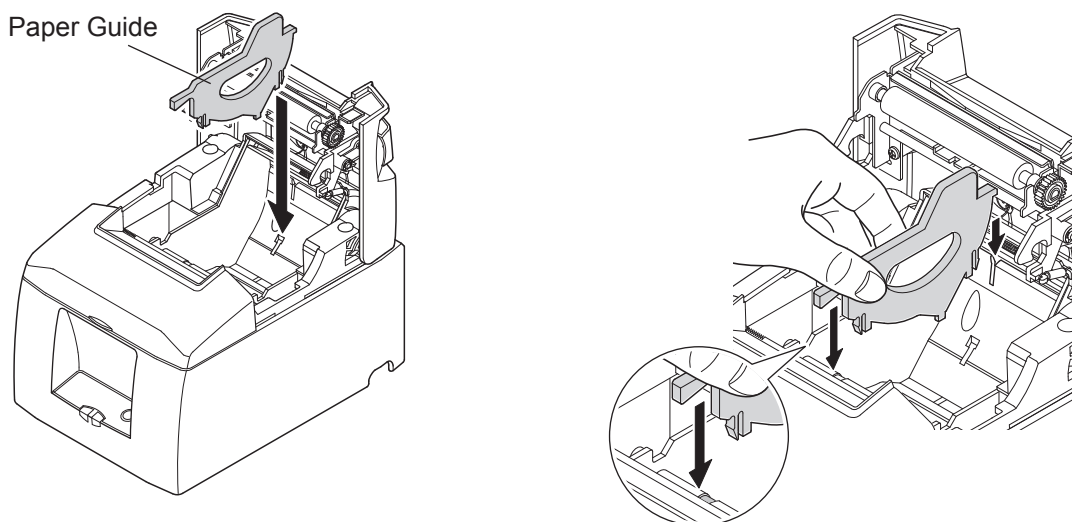

- ② Insert the paper guide by pushing the area marked “A” down until it clicks into place.

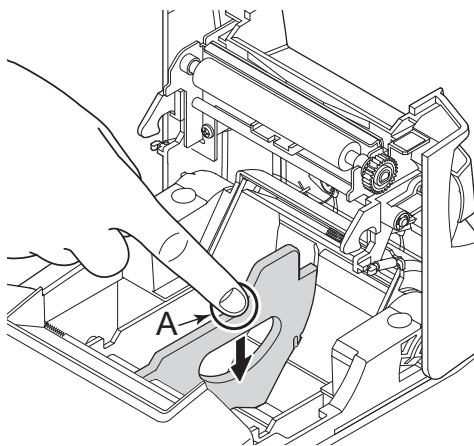

Note: After using a paper roll with a width of 57.5 mm, do not change to a paper roll with a width of 79.5. (This is because the printer head has deteriorated as a result of a portion of the head having been in direct contact with the platen.)

Caution Symbol



These labels are located near the thermal print head.

Because the thermal print head is hot immediately after printing, do not touch it. Static electricity can damage the thermal print head. To protect the thermal print head from static electricity, do not touch it.



This symbol is placed near the cutter.

Never touch the cutter blade, as you could injure your fingers.



This symbol is placed near the peripheral drive connector.

Do not connect this to a telephone.

WARNING

- 1) *Do not touch the cutter blade.*
 - *There is a cutter inside the paper outlet slot. Not only should you not put your hand in the paper outlet slot while printing is in progress, never put your hand into the outlet even when printing is not in progress.*
 - *The printer cover can be opened when replacing the paper. However, since the cutter blade is on the inside of the printer cover, be careful not to place your face or hands too close to the cutter blade.*
- 2) *During and immediately after printing, the area around the thermal head is very hot. Do not touch it, as you could be burned.*

CAUTION

- 1) *Do not operate the cover open lever while pressing on the printer cover with your hand.*
- 2) *Do not push the cover open lever and open the printer cover when printing is in progress or when the auto cutter is operating.*
- 3) *Do not push out paper while the printer cover is closed.*
- 4) *The heating element and the driver IC of the thermal head are easily damaged. Do not touch them with metal objects, sandpaper, etc.*
- 5) *Printing quality may suffer if the thermal head heating element becomes soiled by being touched with your hands. Do not touch the thermal head heating element.*
- 6) *There is a risk of damage to the driver IC of the thermal head from static electricity. Never directly touch the IC.*
- 7) *The printing quality and working life of the thermal head cannot be guaranteed if any paper other than that recommended is used. In particular, paper containing [Na⁺, K⁺, Cl⁻] may drastically reduce the working life of the thermal head. Please exercise caution.*
- 8) *Do not operate the printer if there is moisture on the front surface of the head from condensation, etc.*

- 9) *A printed piece of thermal paper may become electrically charged. If the printer is placed vertically or mounted on a wall, the cut piece of paper may stick to the printer, instead of falling. Beware that this could cause a problem if you use a stacker that stores the pieces of paper that fall freely.*
 - 10) *Do not change the paper width during use. The thermal printing head, rubber roller, and cutter wear differently according to the paper width. This can cause the printing or cutter movement to malfunction.*
 - 11) *Do not transport the printer with its cover open and holding it by the cover.*
 - 12) *Do not forcibly pull on the interface cable, power cable, or cash drawer cable that is connected. To detach a connector, make sure to grasp it at the connector portion, without applying excessive stress on the connector at the printer.*
-

⚠ Notes on Using the Auto Cutter

- 1) *To print after a cut, feed 1 mm (8-dot line) or more of paper.*
 - 2) *If the cutter is not in its home position after an error, first eliminate the cause of the error; then, turn the power back ON.*
 - 3) *A margin of 5 mm or more is recommended from the end of the printed area to the cutting position.*
 - 4) *Do not attempt to remove the paper during a cut, as this can cause a paper jam.*
-

4. Attaching the Accessories

The following accessories are necessary when mounting the printer to a wall.

- Holder plate and two flangeless screws

The following accessories are necessary when positioning the printer vertically.

- Four rubber feet

The following accessories do not necessarily have to be attached. Attach it if necessary.

- Switch cover

4-1. Attaching the Holder Plate

- The holder plate is attached to the printer using the included screws and is hooked onto screws that are installed into the wall.

- The screws on the wall are not included.

Use commercially available screws (4 mm diameter) that are suitable for the wall material (wood, steel beam, concrete, etc.).

- The printer's weight is approximately 2.4 kg when the largest diameter roll paper is loaded.

Use screws on the wall that have both shear strength and pulling-out strength to withstand a force of at least 12 kgf (118 N).

Precautions regarding installation

⚠ CAUTION

This caution indicates information that, if ignored, could lead to personal injury or property damage.

- *Be sure to have qualified personnel install the specified screws and printer to the wall.*

Star is not responsible for any accidents or injuries that occur as a result of improper installation, misuse, or modifications.

Especially when installing the printer at a high location, make sure that the printer is securely installed to the wall.

If the printer is not installed securely and falls, personal injury or damage to the printer may result.

- *Make sure that the mounting surface and installation screws are strong enough to install the printer.*

Securely install the printer so that the weight of the printer and any connected cables will not cause the printer to fall.

Otherwise, personal injury or damage to the printer may result.

- *Do not install the printer in an unstable location or a location that is exposed to vibration and shocks.*

If the printer falls, personal injury or damage to the printer may result.

- (1) Attach the holding plate to the printer. Then tighten the two screws that were supplied to secure it in place.

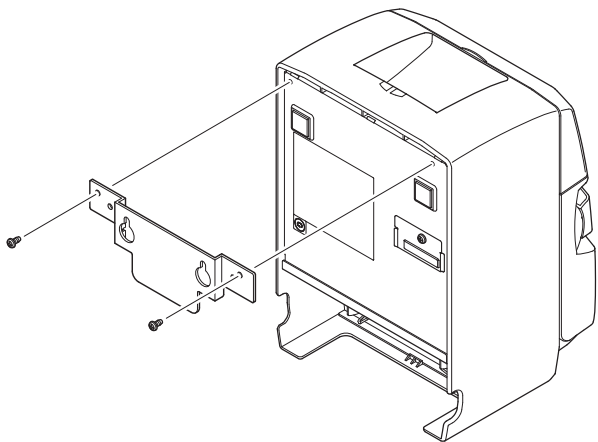

- (2) Position the printer over the screws, etc., on the wall and then slide it downward to set it in place. After setting the printer in place, check the screws on the wall again to make sure that they are able to support the printer's weight.

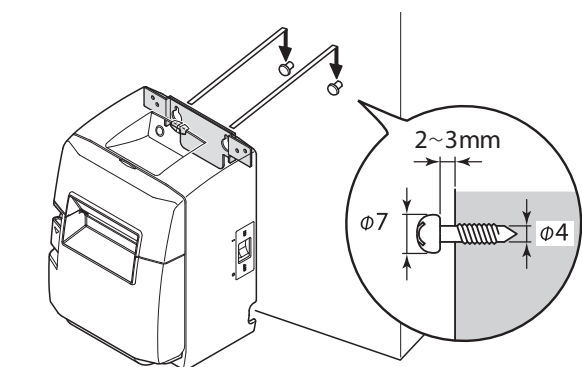

⚠ CAUTION

- The printer's weight is approximately 2.4 kg when the largest diameter roll paper is loaded.
- Use screws on the wall that have both shear strength and pulling-out strength to withstand a force of at least 12 kgf (118 N).

- (3) Push the cover open lever, and open the printer cover.
- (4) Insert the roll paper as shown.

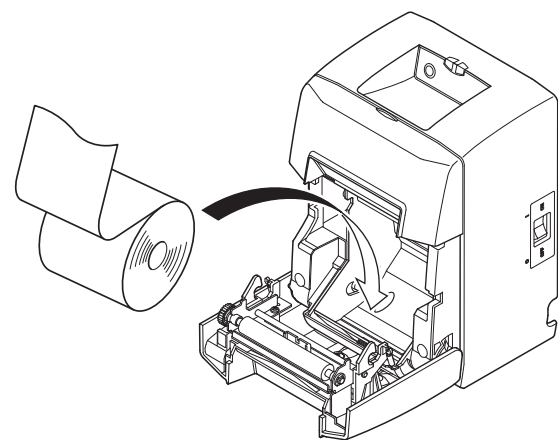

4-2. Attaching the Rubber Feet

- (1) Attach the four rubber feet in the positions shown in the figure. Ensure that any soiling has been completely wiped off before attaching the rubber feet.

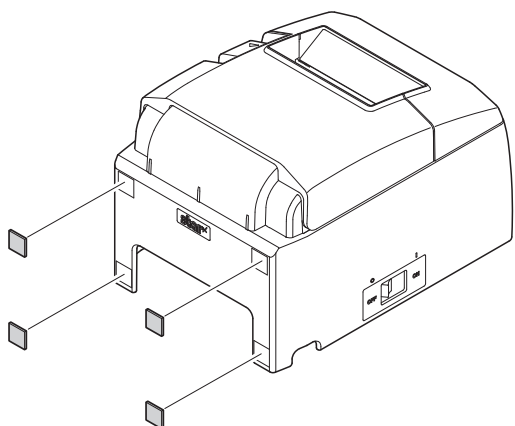

- (2) Push the cover open lever, and open the printer cover.
- (3) Insert the roll paper as shown.

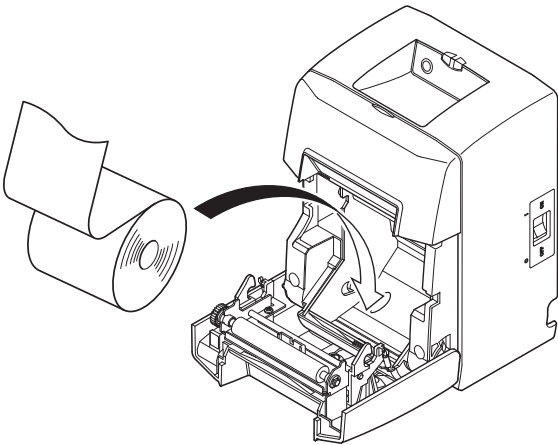

4-3. Switch Cover Installation

It is not necessary to install the switch cover. Only install it if it is necessary for you. By installing the switch cover, the following become possible.

- Preventing the power switch from being operated by mistake.
- Ensuring that other people can not easily operate the power switch.

Install the switch cover as shown in the diagram below.

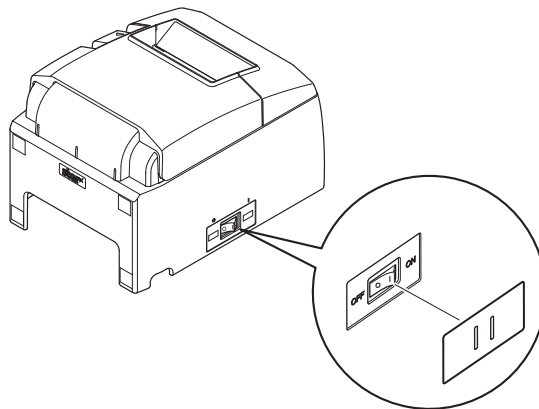

The power switch can be turned ON (I) and OFF (O) by inserting a narrow instrument (ball pen etc.) in the holes in the switch cover.

⚠ CAUTION

We recommend that you unplug the printer from the power outlet whenever you do not plan to use it for long periods. Because of this, you should locate the printer so that the power outlet it is plugged into is nearby and easy to access.

5. Consumable Parts and AC Adapter

When consumable parts have run out, use those specified in the table below.

Note: Access the following URL for the information of the recommended paper.

<http://www.star-m.jp/eng/dl/dl02.htm>

Make sure that the AC adapter specified in the table is used.

Use of consumable parts or AC adapter which are not specified in the table may result in damage to the printer, fire or electric shock.

5-1. Thermal Paper Roll

(1) Paper roll specification

Thermal paper

Thickness: 65~85 μm (excluding Mitsubishi HiTec F5041)

Width: 79.5 \pm 0.5 mm (57.5 \pm 0.5 mm when the paper roller holder is used)

Outer roll diameter: \varnothing 83 mm or less

Take up paper roll width: 80 $^{+0.5}_{-1}$ mm or (58 $^{+0.5}_{-1}$ mm when the paper roller holder is used)

Core outer/inner diameter

Core outer Core inner

\varnothing 18 \pm 1 mm \varnothing 12 \pm 1 mm

Printed surface: Outer edge of roll

Tail end handling: Do not use paste or glue to secure the roll paper or its core.
Do not fold the tail end of the paper.

(2) Effective Print Width

P a p e r Width (mm)	Right / Left Margin (mm)	Effective Print Width (mm)	Number of Print Columns (12 × 24 Font)
79.5 ± 0.5	3.75	72	48
57.5 ± 0.5	Left 2.75, Right 3.75	51	34

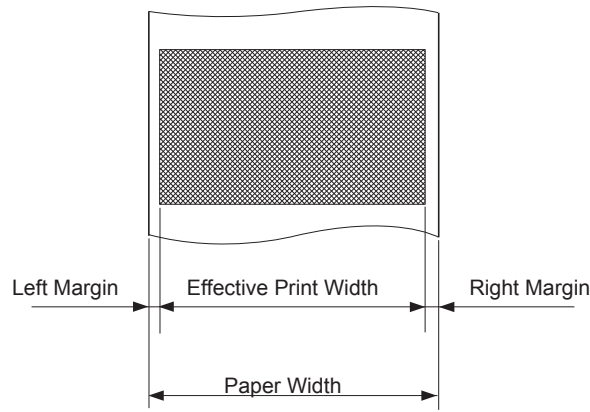

5-2. AC adapter (option)

AC adapter which are not specified may result in damage to the printer, fire or electric shock.

Model name: PS60A-24 series

Input: 90 to 264 V AC, 50/60 Hz

Output: DC24 V ±5%, 2.0 A (5.0 A Load 10 sec. Max.)

6. Control Panel and Other Functions

6-1. Control Panel

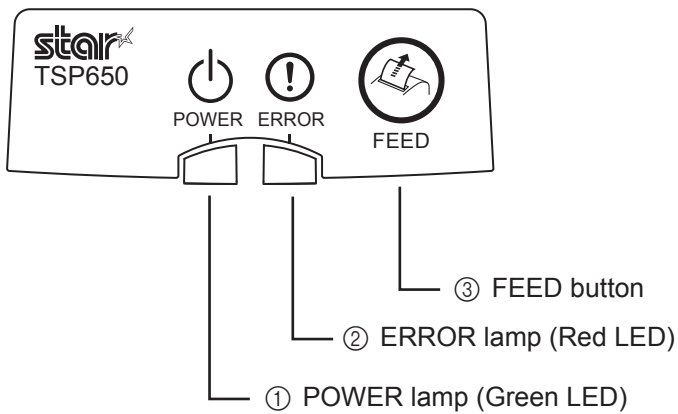

- ① POWER lamp (Green LED)
Lights when the power is ON.
- ② ERROR lamp (Red LED)
Indicates various errors in combination with POWER lamp.
- ③ FEED button
Press the FEED button to feed roll paper.

6-2. Errors

1) Recoverable errors

Error Description	POWER Lamp	E R R O R Lamp	Recovery Conditions
Head high temperature detection	Flashes at 0.5-second intervals	OFF	Automatically recovered after the print head has cooled.
Cover open error	ON	ON	Automatically recovered by closing the printer cover.
Paper out error	ON	Flashes at 0.5 second intervals	Automatically recovered by loading a new paper roll, then closing the printer cover.
Paper near end	ON	Flashes at 2 second intervals	Indicators show that the paper end is approaching, but the printer continues to print.
Paper cut error	OFF	Flashes at 0.125 second intervals	Recovered if the cutter returns to the home position after turning the power OFF and ON. (See Notes 1 and 2.)
Link disconnection detection*1	Flashes at 2-second intervals	Flashes at 2-second intervals	Connect an Ethernet cable. For details, see section 3-2-5, "Ethernet Interface Cable."

*1 Ethernet interface model only

Note:

- 1) If the cutter doesn't return to the home position or doesn't perform the initial movement, it cannot be recovered. See "8-3. Releasing a Locked Cutter (Auto Cutter Mode only)" on page 25 for details.
- 2) If the paper is jammed, turn the power off, clear the jammed paper, then turn the power ON.

2) Non-recoverable errors

Error Description	POWER Lamp	ERROR Lamp	Recovery Conditions
Flash access error	OFF	Flashes at 0.5-second intervals	This is not a recoverable error.
EEPROM error	OFF	Flashes at 0.75-second intervals	This is not a recoverable error.
SRAM error	OFF	Flashes at 1-second intervals	This is not a recoverable error.
Head thermistor error	OFF	Flashes at 1.5-second intervals	This is not a recoverable error.
Power voltage error	OFF	Flashes at 2-second intervals	This is not a recoverable error.

Note:

- 1) If a non recoverable error occurs, turn the power OFF immediately.
- 2) When Power supply error occurs, there is a possibility that the power supply unit has a trouble.

For other non recoverable errors, please consult the dealer for repairs.

6-3. Self-Printing

6-3-1. Test Printing

Place the thermal paper roll on the printer.

Turn the power ON while holding the FEED button depressed. The printer will run a test print according to the Ver. No., DIP switch settings, and memory switch settings, etc.

```
*** TSP650 Ver1.0

Interface : Parallel

-- Dip Switch 1 --
Sw  12345678
On  *****
Off

-- Dip Switch 1 Detail --
1 = Emulation : Star Line/T
5 = INIT Reset : Enable
6 = BUSY : All
7 = ASB : Invalid

-- Memory Switch --
FEEDER10876543210 HEX.
000000000000
<1> 0000000000000000 0000
<2> 0000000000000000 0000
<3> 0000000000000000 0000
<4> 0000000000000000 0000
```

6-3-2. Hexadecimal Dump Mode

Place the thermal paper roll on the printer.

Open the printer cover, then turn the power on while holding the FEED button.

When the cover is closed, “*** HEX DUMP PRINTING ***” is printed, and the printer enters the Hexadecimal Dump Mode.

Each of the signals sent from the computer to the printer will be printed out in hexadecimal code.

This function allows you to check if a control code sent to the printer by the program being used is correct or not. The final line is not printed if its data is less than one full line. However, if the FEED button is pushed, the final line is printed. To turn off the mode, it is necessary to turn off the printer completely.

```
*** HEX DUMP PRINTING ***

00 01 02 03 04 05 06 07      .....
08 09 0A 0B 0C 0D 0E 0F      .....
10 11 12 13 14 15 16 17      .....
18 19 1A 1B 1C 1D 1E 1F      .....
20 21 22 23 24 25 26 27      !"#%&'
28 29 2A 2B 2C 2D 2E 2F      ()*+,-./
30 31 32 33 34 35 36 37      01234567
38 39 3A 3B 3C 0A             89:;<.
```

7. Adjusting the Near-end Sensor

Use the following procedure to adjust the near-end sensor so it is compatible with the size of paper roll you are using.

- ① Open the printer cover.
- ② Determine the diameter of the paper roll you are using and find the required setting in the table below.
- ③ Insert the tip of a ballpoint pen or similar object into the hole of the adjuster, and then push and slide the adjuster to the desired setting.

When changing the setting, make sure that the position of the hole is aligned with the alignment mark indicated by the arrow.

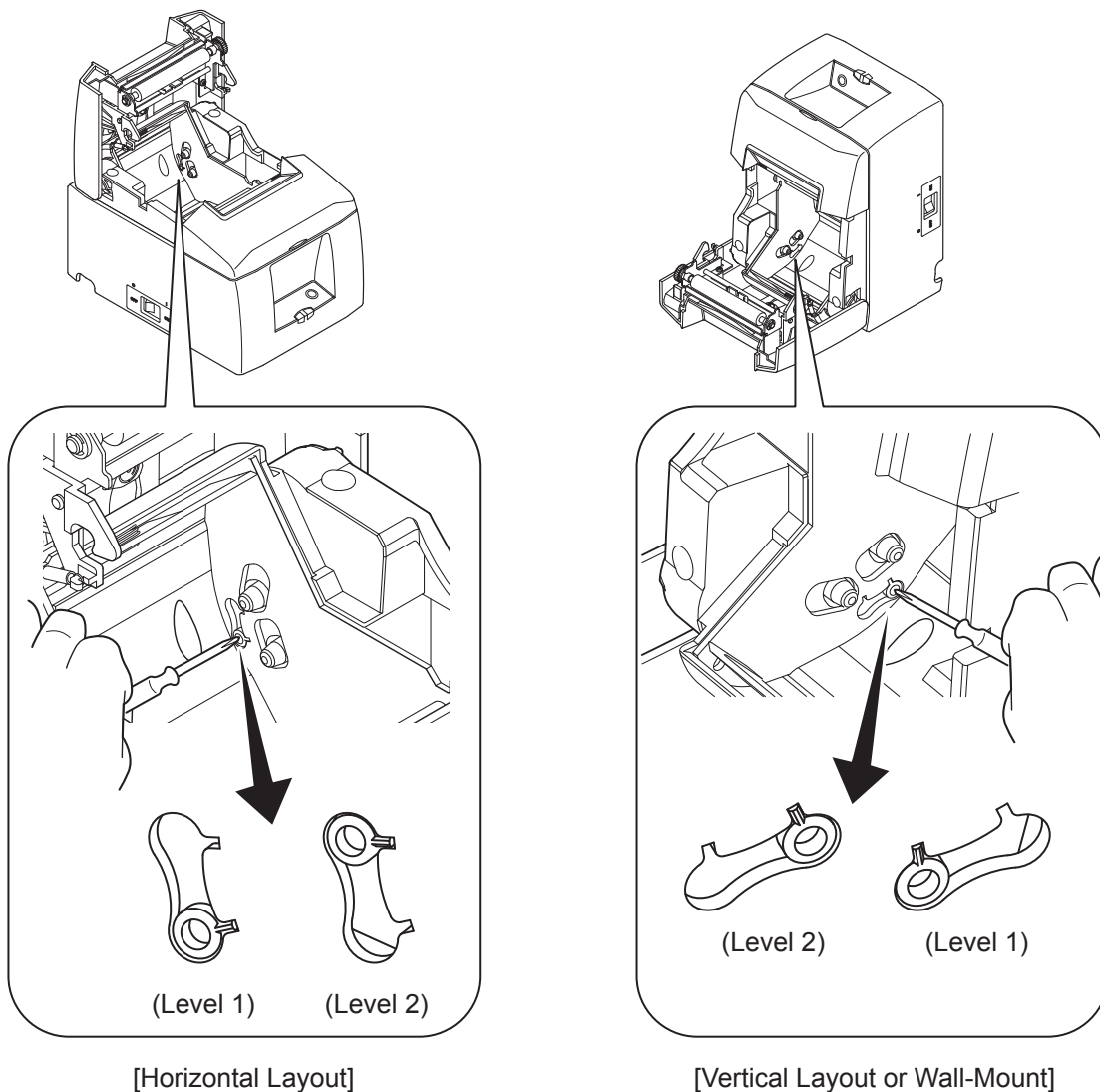

Adjustment value according to the paper you are using

Paper Width (μm)	Horizontal (standard) Layout $\phi 12$ (A) inner diameter / $\phi 18$ (B) outer diameter core roll paper				Vertical Layout or Wall-Mount $\phi 12$ (A) inner diameter / $\phi 18$ (B) outer diameter core roll paper			
	Detected diameter (C) (mm)		Remaining paper length (m)		Detected diameter (C) (mm)		Remaining paper length (m)	
	Level 1	Level 2	Level 1	Level 2	Level 1	Level 2	Level 1	Level 2
65	Approx. $\phi 23$	Approx. $\phi 29$	Approx. 2.5	Approx. 6.3	Approx. $\phi 23$	Approx. $\phi 29$	Approx. 2.5	Approx. 6.3
85	Approx. $\phi 23$	Approx. $\phi 29$	Approx. 1.9	Approx. 4.8	Approx. $\phi 23$	Approx. $\phi 29$	Approx. 1.9	Approx. 4.8

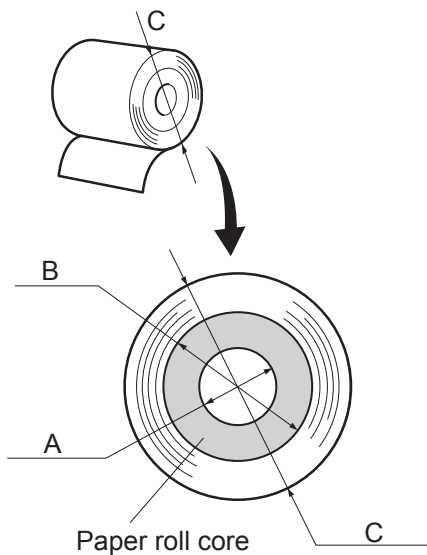

Notes:

- 1) The adjuster is factory-set at level 1.
- 2) The detected diameter and remained paper length given in the table are calculated values, and there are some variances depending on the rolled state of the paper, the actual mechanism, or the printing pattern.
- 3) If thick paper is used (paper thickness between $80 \mu\text{m}$ and $85 \mu\text{m}$), the paper roll may loosen and cause variances in the detected values. Therefore, setting the adjuster to Level 2 is recommended.

8. Preventing and Clearing Paper Jams

8-1. Preventing Paper Jams

The paper should not be touched during ejection and before it is cut.

Pressing or pulling the paper during ejection may cause a paper jam, paper cutting failure or line feed failure.

8-2. Removing Paper Jam

If a paper jam occurs, clear it as described below.

- (1) Set the power switch to off to turn off power to the printer.
- (2) Push the lever toward you to open the printer cover.
- (3) Remove the jammed paper.

Note: To prevent parts such as the thermal head or the rubber roller from damage or deformation, do not forcibly pull on the paper with the printer cover closed.

- (4) Position the paper roll straight and close the printer cover gently.

Note 1: Make sure that the paper is positioned straight. If the printer cover is closed with the paper skewed, a paper jam may result.

Note 2: Lock the printer cover by pressing down on the sides. Do not try to close it by pressing down on the centre. The cover may not lock properly.

- (5) Set the power switch to on to turn on power to the printer. Make sure that the ERROR LED is not lit.

Note: While the ERROR LED is lit, the printer will not accept any commands such as the print command, so make sure that the printer cover is locked properly.

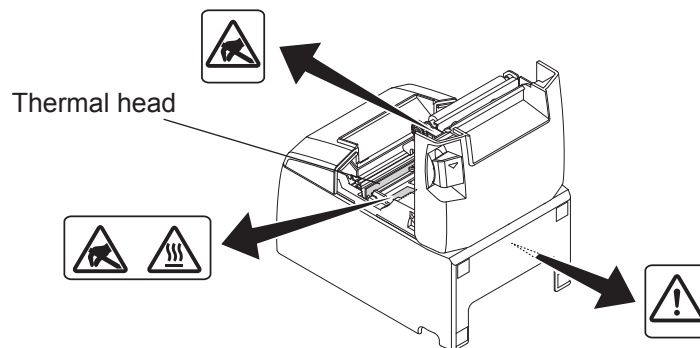

These labels are located near the thermal print head.

Because the thermal print head is hot immediately after printing, do not touch it. Static electricity can damage the thermal print head. To protect the thermal print head from static electricity, do not touch it.



This symbol is placed near the cutter.

Never touch the cutter blade, as you could injure your fingers.



This symbol is placed near the peripheral drive connector.

Do not connect this to a telephone.

8-3. Releasing a Locked Cutter (Auto Cutter Mode only)

If the auto cutter locks up, set the power switch to OFF to turn off the printer, and then set the power switch to ON to turn the printer back on. A typical locked cutter will be restored when you restart the printer.

If restarting the printer does not release the locked cutter, follow the steps below.

⚠ WARNING

Since working on the cutter may be dangerous, be sure to turn off the printer first.

- (1) Set the power switch to OFF to turn off the printer.
- (2) Remove the front cover to reveal the auto cutter.
- (3) Remove any jammed paper.

Note: Be careful not to damage the printer while removing any jammed paper. Since the thermal print head is particularly sensitive, be sure not to touch it.

- (4) Insert a Philips screwdriver into the manual operation hole on the side of the cutter, and turn it in the direction of the arrow shown on the right until the rear cover is opened.
- (5) Open the printer cover, remove any jammed paper, and then reinstall the paper roll.
- (6) Install the front cover, and then set the power switch to ON.

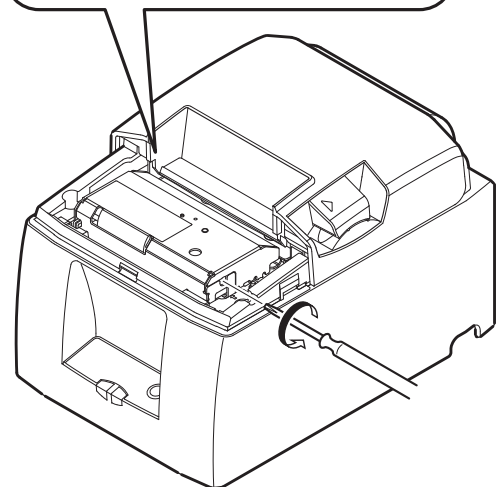
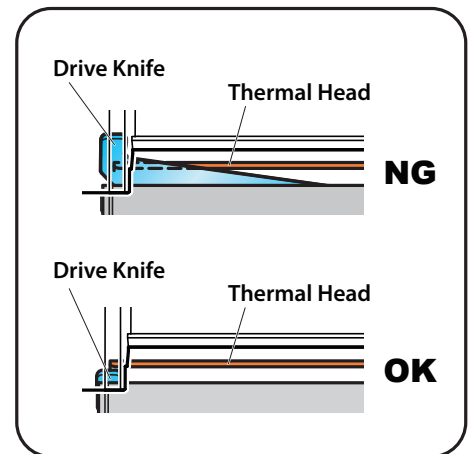
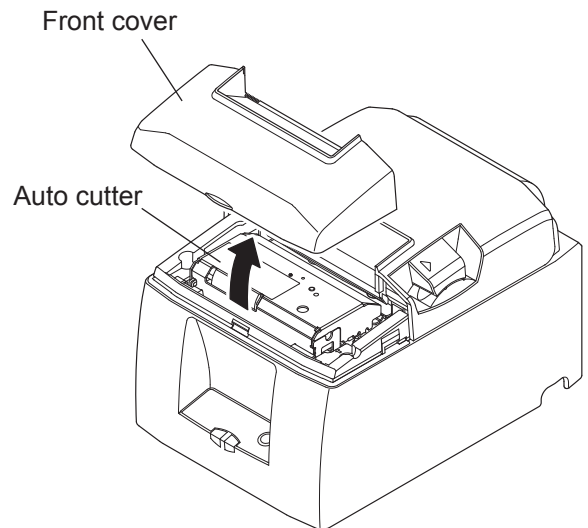

9. Periodical Cleaning

Printed characters may become partially unclear due to accumulated paper dust and dirt. To prevent such a problem, paper dust collected in the paper holder and paper transport section and on the surface of the thermal head must be removed periodically.

Such cleaning is recommended to be carried out once six month or one million lines.

9-1. Cleaning the Thermal Head

To remove the dark paper dust that has accumulated on the thermal head surface, wipe it clean with cotton swab (or soft cloth) dipped in alcohol (ethanol, methanol, or isopropyl alcohol).

Note 1: The thermal head is easily damaged, so clean it with a soft cloth, taking care not to scratch it.

Note 2: Do not attempt to clean the thermal head immediately after printing, when the thermal head is hot.

Note 3: Beware of the risk of damaging the thermal head as a result of static electricity that may be created during cleaning.

Note 4: Turn the power ON only after the alcohol has dried completely.

9-2. Cleaning the Rubber Roller

Use a dry, soft cloth to wipe off the dust that may have accumulated on the rubber roller. Rotate the platen to clean the entire surface.

9-3. Cleaning the Paper Holder and the Surrounding Area

Clean the paper holder of debris, dust, paper particles, glue, etc. that may have accumulated.

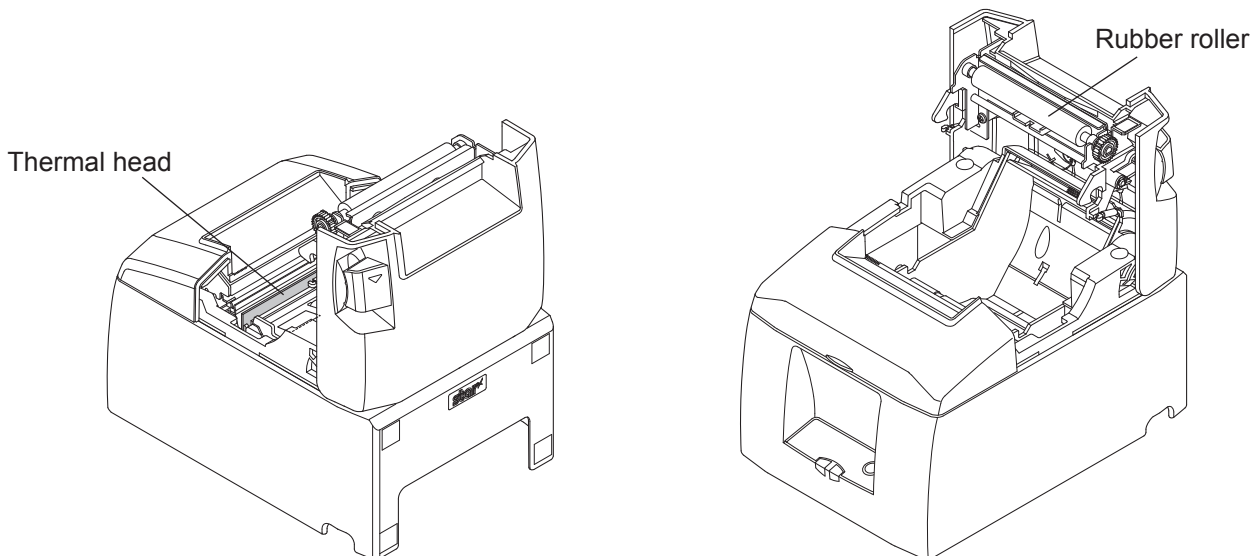

10. Specifications

10-1. General Specifications

(1) Printing method	Direct line thermal printing
(2) Print speed	Max. 1200 dots/sec. (150 mm/sec.)
(3) Dot density	203 dpi: 8 dots/mm (0.125 mm/dot)
(4) Printing width	Max. 72 mm
(5) Number of print columns	48 (12 × 24 dots)
(6) Paper feed method	Friction feed
(7) Paper roll	Refer to chapter 5 for details on the recommended paper roll. Paper width: 79.5 ± 0.5 or 57.5 ± 0.5 mm Roll diameter: $\varnothing 83$ mm or less
(8) Overall dimension	142 (W) × 202 (D) × 132 (H) mm
(9) Weight	Auto cutter model : 1.72 kg (without roll paper) Tear bar model : 1.56 kg (without roll paper)
(10) Noise	Auto cutter model : Approx. 50 dB Tear bar model : Approx. 53 dB

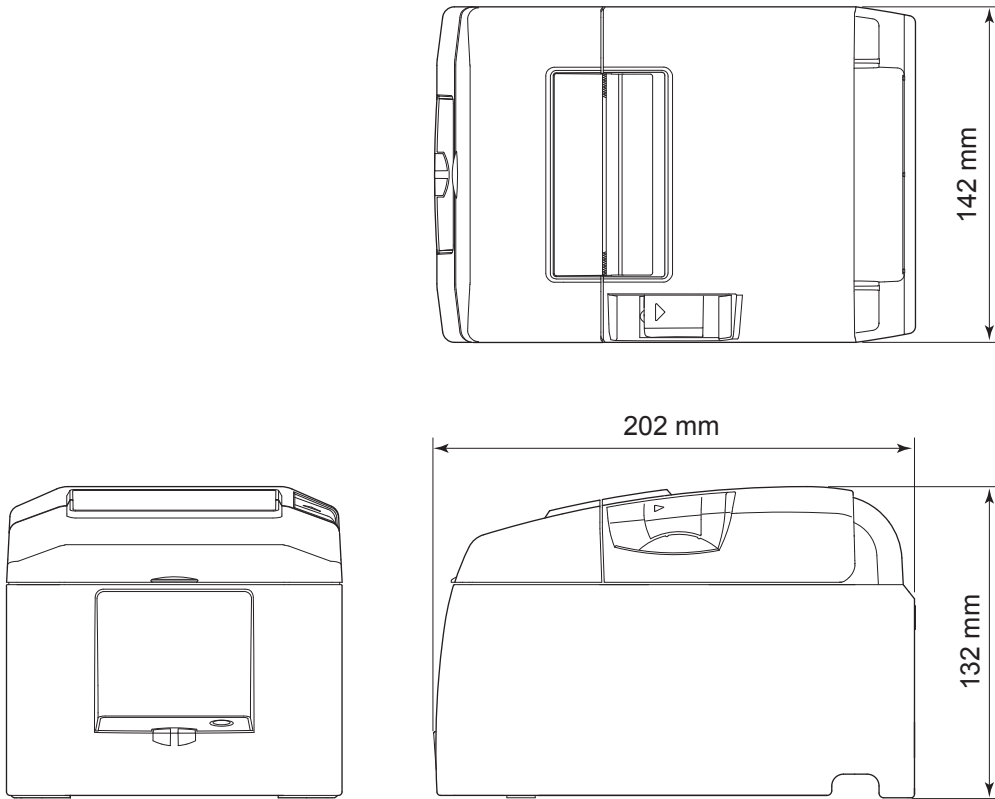

10-2. Auto Cutter Specifications

- | | |
|------------------------|---|
| (1) Cutting Modes | Partial cut (leaves one uncut portion in center of paper) |
| (2) Cutting Duty | Min. 3 seconds/cut |
| (3) Thickness of paper | 0.065 ~ 0.085 mm |

10-3. Interface

RS-232C serial interface / Two-way parallel interface (IEEE1284)

10-4. Electrical Characteristics (AC adapter)

- | | |
|---|--|
| (1) Input: | 100 to 240 V AC, 50/60 Hz |
| (2) Output: | DC 24 V \pm 5% |
| (3) Current Consumption (DC 24 V at room temperature) | |
| Standby: | Approx. 0.15 A |
| ASCII printing: | Approx. average 1.7 A
(Approx. 17.5% printing rate) |
| 100% print duty: | Approx. peak 9.0 A
(Solid printing): Approx. average 5.0 A
(Continuous solid printing should be 10 seconds or less.) |
| (4) Power Connector | |

Pin No.	Function
1	Drive power (24 V)
2	Signal GND
3	N.C.
Shell	Frame ground

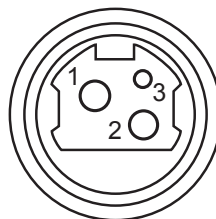

<Viewed from Connector Surface>

Note:

- When using a printer power supply other than the optional AC adapter (PS60A-24 series), be sure that the following cautions are observed.
- Use a power supply of DC 24 V \pm 5% and more than 2.0 A (5.0 A Load 10 sec. Min.) with SELV output and LPS or Class 2 output approved by IEC60950.
- Be careful about installing the printer in an area where there is noise. Take the appropriate measures to protect against electrostatic AC line noise, etc.

10-5. Environmental Requirements

- (1) Operating
Temperature 5°C to 45°C
Humidity 10% to 90% RH (without condensation)

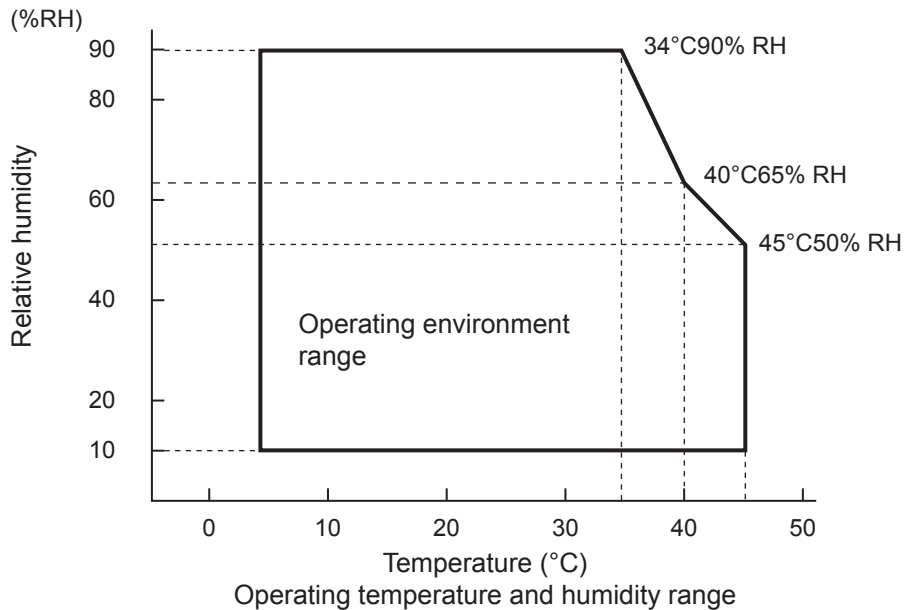

- (2) Transport/storage (except for paper)
Temperature -20°C to 60°C
Humidity 10% to 90% RH (without condensation)

* However, the combination of 40°C and 90% RH (no condensation) is considered the worst value regarding high temperatures and humidity.

10-6. Reliability Specifications

- 1) Life
- | | |
|--------------|--|
| Mechanical: | 20 million lines |
| Head: | 100 million pulses, 100 km ($\pm 15\%$ max. average head resistance fluctuation)
For 2-color printing, 50 million pulses, 50 km ($\pm 15\%$ max. average head resistance fluctuation) |
| Auto cutter: | 1 million cuttings (provided the paper thickness is between 65 and 85 μm) |

<Conditions>

Average printing ratio: 12.5%

Recommended thermal paper: 65 μm

- 2) MCBF: 60 million lines

The Mean Cycle Between Failure (MCBF) is defined to be the overall failure cycle, which includes random or wear failures that occur until the printer reaches its mechanical life of 20 million lines.

- * As the mechanical remains at 20 million lines, the MCBF of 60 million lines does not indicate its useful life.

- 3) Auto Cutter (Life)

1 million cuttings (provided the paper thickness is between 65 and 85 μm)

- * All the reliability values indicated above are based on the use of the recommended thermal paper. No reliability can be guaranteed for the use of non-recommended thermal paper.

11. Dip Switch Setting

Two DIP switches are provided at the bottom of the printer, and can be set as given in the table below. Be sure to set the power switch to off before changing the settings. It is recommended to use a pointed item like a pen or flat-blade driver screw to change the settings. The settings will become effective when the power switch is set to on again.

The following is the procedure for changing the settings on DIP switches.

1. Make sure the printer is turned off.
2. Remove the screw from the DIP switch blind. Then take off the DIP switch blind, as shown in the illustration below.

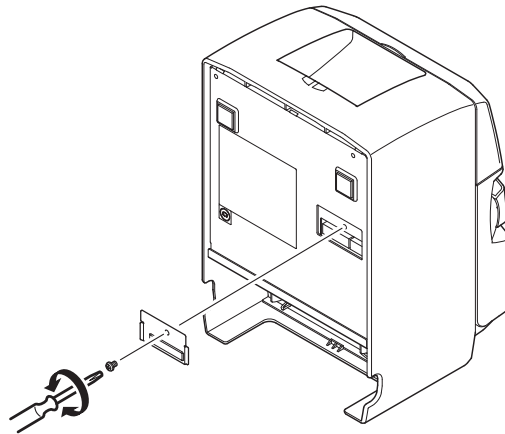

3. Set the switches using a pointed tool, such as a pen or flat-blade screwdriver.
4. Replace the DIP switch blind. Then secure it with the screw. The new settings take effect when you turn on the printer.

11-1. Parallel Interface Model

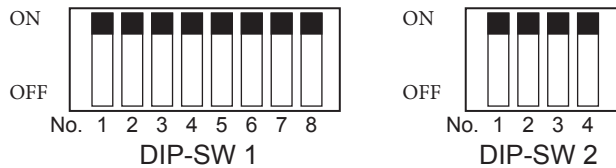

DIP-SW 1

Switch 1-1	Command emulation
ON	Star Mode
OFF	ESC/POS Mode

The factory settings of DIP switch are all on.

The functions of switches 1-2 through 1-8 will change according to the command emulation that has been set using switch 1-1.

(1) Star mode

Switch	Function	ON	OFF
1-1	Command emulation	Always ON	
1-2	Should not be changed (Should be set to on)		
1-3	Should not be changed (Should be set to on)		
1-4	Sensor adjustment	Invalid	Valid
1-5	Pin #31 (INIT) reset signal	Valid	Invalid
1-6	Handshaking conditions (conditions for BUSY)	Offline or receive buffer full	Receive buffer full
1-7	ASB function *1	Invalid	Valid
1-8	NSB function *2	Invalid	Valid

(2) ESC/POS mode

Switch	Function	ON	OFF
1-1	Command emulation	Always OFF	
1-2	Graphic adjustment	203 DPI	180 DPI
1-3	Should not be changed (Should be set to on)		
1-4	Sensor adjustment	Invalid	Valid
1-5	Pin #31 (INIT) reset signal	Valid	Invalid
1-6	Handshaking conditions (conditions for BUSY)	Offline or receive buffer full	Receive buffer full
1-7	ASB function *1	Invalid	Valid
1-8	Should not be changed (Should be set to on)		

*1 ASB Function

When this function is enabled, status information is automatically sent to the host whenever the printer status changes (such as when the cover is opened, paper runs out, or an error occurs). For information about automatic status information transmission, refer to the separate Programmer's Manual (Star Line Mode and ESC/POS Mode).

***2 NSB Function**

When this function is enabled, status information is sent automatically whenever the printer enters into reverse forwarding mode.

For information about automatic status information transmission, refer to the separate Programmer's Manual (Star Line Mode).

DIP-SW 2

Switch	Function	ON	OFF
2-1	Always ON	Should be set to on	
2-2			
2-3			
2-4			

The factory settings of DIP switch are all on.

11-2. RS-232C Interface Model

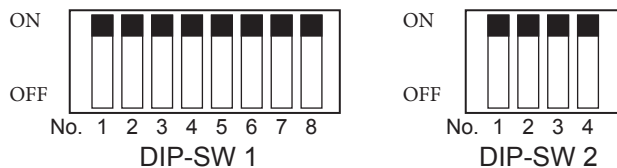

DIP-SW 1

Switch 1-1	Command emulation
ON	Star Mode
OFF	ESC/POS Mode

The factory settings of DIP switch are all on.

The functions of switches 1-2 through 1-8 will change according to the command emulation that has been set using switch 1-1.

(1) Star mode

Switch	Function	ON	OFF
1-1	Command emulation	Always ON	
1-2	Should not be changed (Should be set to on)		
1-3	Should not be changed (Should be set to on)		
1-4	Sensor adjustment	Invalid	Valid
1-5	Should not be changed (Should be set to on)		
1-6	Handshaking conditions (conditions for BUSY)	Offline or receive buffer full	Receive buffer full
1-7	ASB function *1	Invalid	Valid
1-8	Should not be changed (Should be set to on)		

(2) ESC/POS mode

Switch	Function	ON	OFF
1-1	Command emulation	Always OFF	
1-2	Graphic adjustment	203 DPI	180 DPI
1-3	Should not be changed (Should be set to on)		
1-4	Sensor adjustment	Invalid	Valid
1-5	Should not be changed (Should be set to on)		
1-6	Handshaking conditions (conditions for BUSY)	Offline or receive buffer full	Receive buffer full
1-7	ASB function *1	Invalid	Valid
1-8	Should not be changed (Should be set to on)		

*1 ASB Function

When this function is enabled, status information is automatically sent to the host whenever the printer status changes (such as when the cover is opened, paper runs out, or an error occurs). For information about automatic status information transmission, refer to the separate Programmer's Manual (Star Line Mode and ESC/POS Mode).

DIP-SW 2

Switch	Function	ON	OFF
2-1	Always ON		Should be set to on
2-2			
2-3			
2-4			

The factory settings of DIP switch are all on.

The following is the procedure for changing the settings on DIP switch No. 3.

1. Turn off the printer and all components connected to it.
2. Remove the 2 screws.
3. Remove the serial interface board unit.
4. Change the setting of the DIP switches.
5. Replace the serial interface board unit.
Then secure it with the screws.
6. Turn on the printer and all components connected to it.

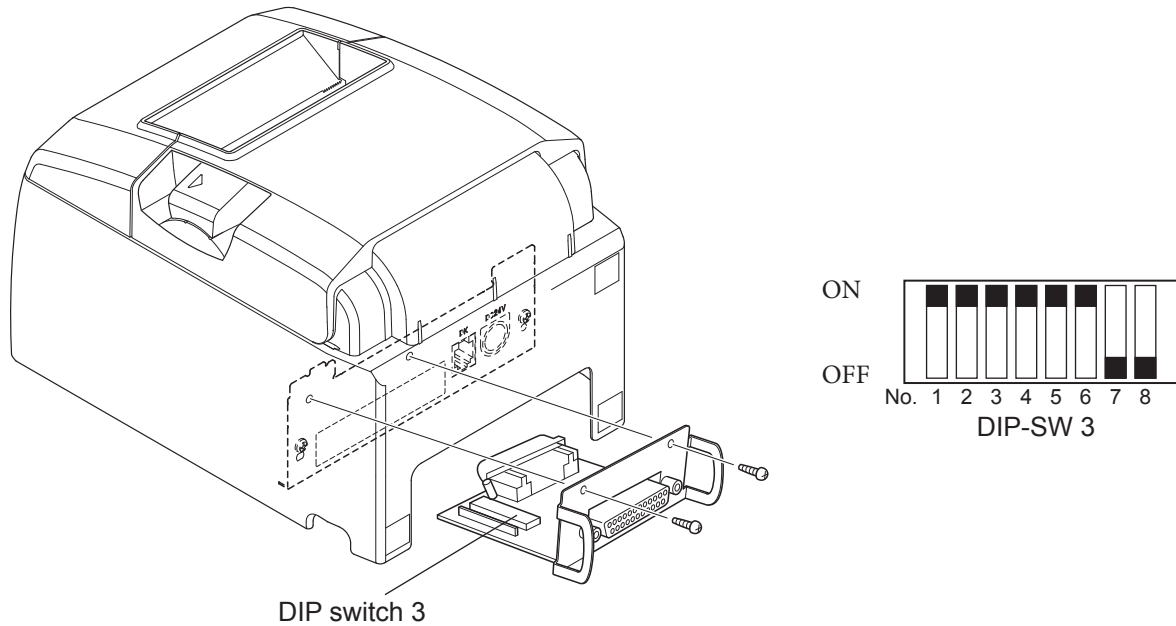

The factory settings of DIP switch are all on, except for switches 7 and 8.

DIP-SW 3

Switch	Function	ON	OFF
3-1	Baud Rate	See table below	
3-2			
3-3	Data Length	8 bits	7 bits
3-4	Parity Check	Disabled	Enabled
3-5	Parity	Odd	Even
3-6	Handshake	DTR/DSR	XON/XOFF
3-7	Should not be changed (Should be set to off)	—	—
3-8			

Baud Rate	Switch 3-1	Switch 3-2
4800BPS	OFF	ON
9600BPS	ON	ON
19200BPS	ON	OFF
38400BPS	OFF	OFF

11-3. USB Interface Model

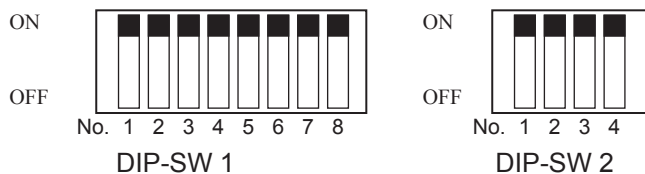

DIP-SW 1

Switch 1-1	Command emulation
ON	Star Mode
OFF	ESC/POS Mode

The factory settings of DIP switch are all on.

The functions of switches 1-2 through 1-8 will change according to the command emulation that has been set using switch 1-1.

(1) Star Line Mode

Switch	Function	ON	OFF	
1-1	Command emulation	Always ON		
1-2	Should not be changed (Should be set to on)			
1-3	Should not be changed (Should be set to on)			
1-4	Sensor adjustment	Invalid	Valid	
1-5	USB mode	Printer class	Vendor class	
1-6	Handshaking conditions (conditions for BUSY)	Offline or receive buffer full	Receive buffer full	
1-7	ASB function *1	Printer class	Valid	Invalid
		Vendor class	Invalid	Valid
1-8	NSB function *2	Printer class	Valid	Invalid
		Vendor class	Invalid	Valid

*1 ASB Function

When this function is enabled, status information is automatically sent to the host whenever the printer status changes (such as when the cover is opened, paper runs out, or an error occurs). For information about automatic status information transmission, refer to the separate Programmer's Manual (Star Line Mode and ESC/POS Mode).

*2 NSB Function

When this function is enabled, status information is sent automatically whenever the printer enters into reverse forwarding mode.

For information about automatic status information transmission, refer to the separate Programmer's Manual (Star Line Mode).

(2) ESC/POS mode

Switch	Function	ON	OFF
1-1	Command emulation	Always OFF	
1-2	Graphic adjustment	203 DPI	180 DPI
1-3	Should not be changed (Should be set to on)		
1-4	Sensor adjustment	Invalid	Valid
1-5	USB mode	Printer class	Vendor class
1-6	Handshaking conditions (conditions for BUSY)	Offline or receive buffer full	Receive buffer full
1-7	ASB function *1	Printer class	Invalid
		Vendor class	Valid
1-8	Should not be changed (Should be set to on)		

*1 ASB Function

When this function is enabled, status information is automatically sent to the host whenever the printer status changes (such as when the cover is opened, paper runs out, or an error occurs). For information about automatic status information transmission, refer to the separate Programmer's Manual (Star Line Mode and ESC/POS Mode).

DIP-SW 2

Switch	Function	ON	OFF
2-1	Always ON	Should be set to on	
2-2			
2-3			
2-4			

The factory settings of DIP switch are all on.

11-4. EthernetInterface Model

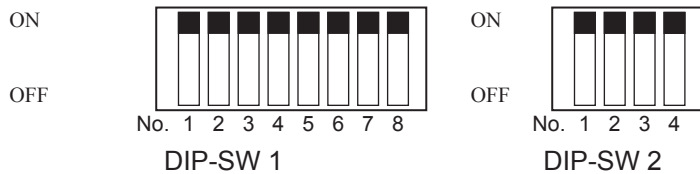

DIP-SW 1

Switch 1-1	Command emulation
ON	Star Mode
OFF	ESC/POS Mode

The factory settings of DIP switch are all on.

The functions of switches 1-2 through 1-8 will change according to the command emulation that has been set using switch 1-1.

(1) Star Line Mode

Switch	Function	ON	OFF
1-1	Command emulation	Always ON	
1-2	Should not be changed (Should be set to on)		
1-3	Should not be changed (Should be set to on)		
1-4	Sensor adjustment	Invalid	Valid
1-5	Should not be changed (Should be set to on)		
1-6	Handshaking conditions (conditions for BUSY)	Offline or receive buffer full	Receive buffer full
1-7	ASB function *1	Valid	Invalid
1-8	NSB function *2	Valid	Invalid

*1 ASB Function

When this function is enabled, status information is automatically sent to the host whenever the printer status changes (such as when the cover is opened, paper runs out, or an error occurs). For information about automatic status information transmission, refer to the separate Programmer's Manual (Star Line Mode and ESC/POS Mode).

*2 NSB Function

When this function is enabled, status information is sent automatically whenever the printer enters into reverse forwarding mode.

For information about automatic status information transmission, refer to the separate Programmer's Manual (Star Line Mode).

(2) ESC/POS mode

Switch	Function	ON	OFF
1-1	Command emulation	Always OFF	
1-2	Graphic adjustment	203 DPI	180 DPI
1-3	Should not be changed (Should be set to on)		
1-4	Sensor adjustment	Invalid	Valid
1-5	Should not be changed (Should be set to on)		
1-6	Handshaking conditions (conditions for BUSY)	Offline or receive buffer full	Receive buffer full
1-7	ASB function *1	Valid	Invalid
1-8	Should not be changed (Should be set to on)		

*1 ASB Function

When this function is enabled, status information is automatically sent to the host whenever the printer status changes (such as when the cover is opened, paper runs out, or an error occurs). For information about automatic status information transmission, refer to the separate Programmer's Manual (Star Line Mode and ESC/POS Mode).

DIP-SW 2

Switch	Function	ON	OFF
2-1	Always ON	Should be set to on	
2-2			
2-3			
2-4			

The factory settings of DIP switch are all on.

■ Initializing Settings

Set the push switch as described below to initialize the setting information.

Push the switch for one to five seconds while running under normal operating mode. The green and red LEDs will flash with a regular pattern. After that, push the switch once again in that state to turn OFF both of the red and green LEDs. This will return the settings of the interface board to their default, or ex-factory, settings. After the interface board has been initialized, the printer will automatically reboot itself.

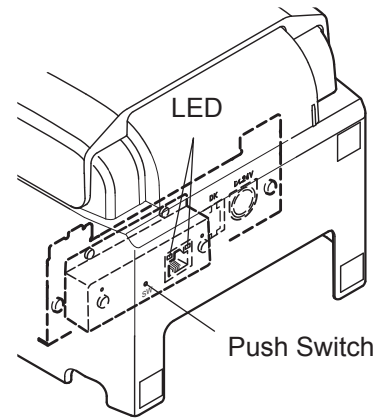

■ LED Display

Green : Lights when other party connection is recognized as 100BASE-TX.

Red : Lights when packets are received.

12. Parallel Interface

The two-way parallel interface is compatible with the IEEE1284 compatibility mode and nibble mode. Contact your dealer for details.

Table of Connection Signals for Each Mode

Pin No.	Direction	Compatibility Mode Signal Name	Nibble Mode Signal Name
1	In	nStrobe	Host Clock
2	In/Out	Data0	Data0
3	In/Out	Data1	Data1
4	In/Out	Data2	Data2
5	In/Out	Data3	Data3
6	In/Out	Data4	Data4
7	In/Out	Data5	Data5
8	In/Out	Data6	Data6
9	In/Out	Data7	Data7
10	Out	nAck	PtrClk
11	Out	Busy	PtrBusy/Data3,7
12	Out	PError	AckDataReq/Data2,6
13	Out	Select	Xflag/Data1,5
14		—	HostBusy
15		—	—
16		Signal GND	Signal GND
17		Frame GND	Flame GND
18	OUT	+5 V	+5 V
19~30		Twisted Pair Return	Twisted Pair Return
31	In	nInit	nInit
32	Out	nFault	nDataAvail/Data0,4
33		External GND	—
34		—	—
35		—	—
36	In	nSelectIn	1284Active

Note:

1. The prefix “n” on the signal name refers to low active signals. If the host does not have any one of the signal lines listed above, two-way communication fails.
2. For interfacing, signal lines should always use twisted pair cables with the return sides connected to the signal ground level.

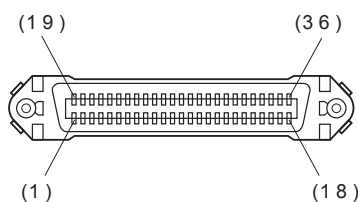

This connector mates with an Amphenol 57-30360 connector

Parallel interface connector (printer side)

13. RS-232C Serial Interface

13-1. Interface Specifications

- ① Data transmission method: Asynchronous serial interface
- ② Baud rate: Selectable from 4800, 9600, 19200, 38400 bps
(Refer to “11. DIP Switch Setting”.)
- ③ Word length
Start bit: 1 bit
Data bit: 7 or 8 bits (selectable.)
Parity bit: Odd, even or none (selectable.)
Stop bit: 1 bit length
- ④ Signal polarity
RS-232C
MARK: Logic “1” (−3 V to −15 V)
SPACE: Logic “0” (+3 V to +15 V)

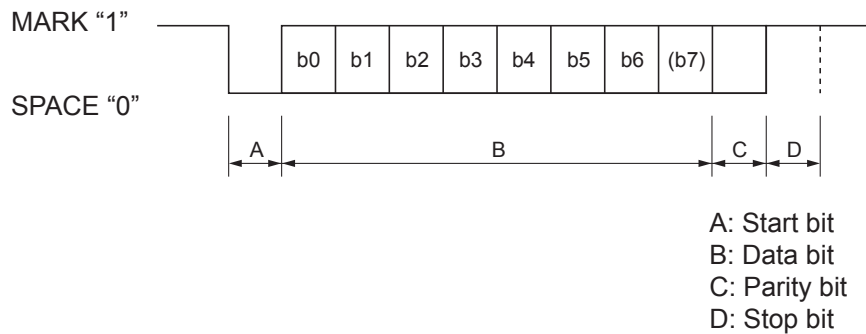

13-2. RS-232C Connector

Pin No.	Signal name	Direction	Function
1	F-GND	—	Frame ground
2	TXD	OUT	Transmission data
3	RXD	IN	Receive data
4	RTS	OUT	Always SPACE
5	N/C		Not used.
6	DSR	IN	<p>1) STAR Mode Not used.</p> <p>2) ESC/POS Mode <i>When DIP Switch 3-7 = OFF;</i> A) DTR/DSR communication mode Indicates whether data receive from host is enabled or disabled. Space: Receive enabled Mark: Receive disabled (except when transmitting data by DLE EOT, and GS a) B) X-ON/X-OFF communication mode Status of this signal is not checked.</p> <p><i>When DIP Switch 3-7 = ON;</i> This is an externally reset signal. A space above 1 ms pulse width engages reset.</p>
7	S-GND	—	Signal ground
8~19	N/C		Not used.
20	DTR	OUT	<p>1) STAR Mode A) DTR/DSR communication mode Indicates whether data receive from host is enabled or disabled. Space: Receive enabled Mark: Receive disabled</p> <p>B) X-ON/X-OFF communication mode Always space, except during following conditions:</p> <ul style="list-style-type: none"> • Period between reset and communication enabled • During self printing

Pin No.	Signal name	Direction	Function																													
			<p>2) ESC/POS Mode</p> <p>A) DTR/DSR communication mode Indicates whether data receive from host is enabled or disabled. Space: Receive enabled Mark: Receive disabled</p> <p>The busy condition can be changed by using Memory switch as follows:</p> <table border="1"> <thead> <tr> <th rowspan="2">Printer status</th> <th colspan="2">Memory SW 4-4</th> </tr> <tr> <th>OFF</th> <th>ON</th> </tr> </thead> <tbody> <tr> <td>1. During the period from when the power is turned on (including resetting using the interface) to when the printer is ready to receive data.</td> <td>BUSY</td> <td>BUSY</td> </tr> <tr> <td>2. During the self printing.</td> <td>BUSY</td> <td>BUSY</td> </tr> <tr> <td>3. When the cover is open.</td> <td>—</td> <td>BUSY</td> </tr> <tr> <td>4. During the paper feeding by FEED button.</td> <td>—</td> <td>BUSY</td> </tr> <tr> <td>5. When the printer stops printing due to a paper-end.</td> <td>—</td> <td>BUSY</td> </tr> <tr> <td>6. During macro executing standby status.</td> <td>—</td> <td>BUSY</td> </tr> <tr> <td>7. When an error has occurred.</td> <td>—</td> <td>BUSY</td> </tr> <tr> <td>8. When the receive buffer becomes full.</td> <td>BUSY</td> <td>BUSY</td> </tr> </tbody> </table> <p>B) X-On/X-Off Communication Mode Always space, except during following conditions:</p> <ul style="list-style-type: none"> • Period between reset and communication enabled • During self printing 	Printer status	Memory SW 4-4		OFF	ON	1. During the period from when the power is turned on (including resetting using the interface) to when the printer is ready to receive data.	BUSY	BUSY	2. During the self printing.	BUSY	BUSY	3. When the cover is open.	—	BUSY	4. During the paper feeding by FEED button.	—	BUSY	5. When the printer stops printing due to a paper-end.	—	BUSY	6. During macro executing standby status.	—	BUSY	7. When an error has occurred.	—	BUSY	8. When the receive buffer becomes full.	BUSY	BUSY
Printer status	Memory SW 4-4																															
	OFF	ON																														
1. During the period from when the power is turned on (including resetting using the interface) to when the printer is ready to receive data.	BUSY	BUSY																														
2. During the self printing.	BUSY	BUSY																														
3. When the cover is open.	—	BUSY																														
4. During the paper feeding by FEED button.	—	BUSY																														
5. When the printer stops printing due to a paper-end.	—	BUSY																														
6. During macro executing standby status.	—	BUSY																														
7. When an error has occurred.	—	BUSY																														
8. When the receive buffer becomes full.	BUSY	BUSY																														
21~24	N/C		Not used.																													
25	$\overline{\text{INIT}}$	IN	<p>When DIP Switch 3-8 = OFF; Status of this signal is not checked. When DIP Switch 3-8 = ON; This is an externally reset signal. A space above 1 ms pulse width engages reset.</p>																													

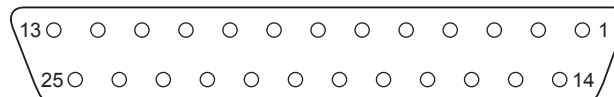

D-sub 25 Pin

13-3. Cable Connections

The followings are a recommended interface cable connections.

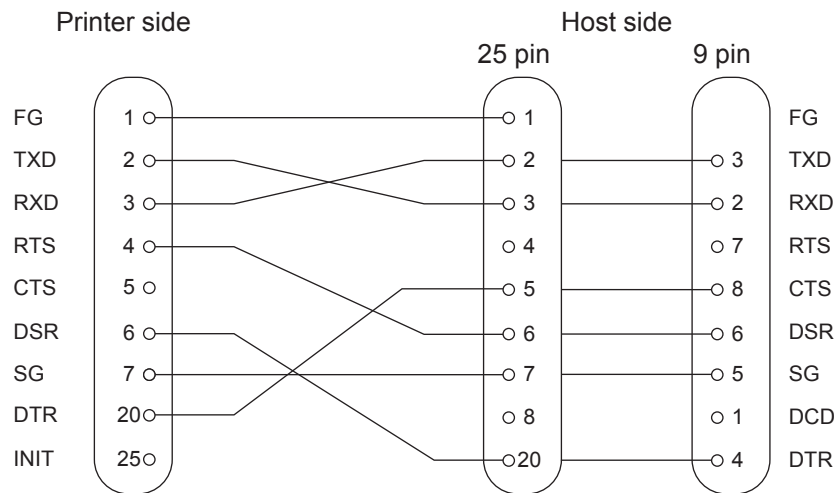

Note: Use shielded wire less than 3 m in length.

14. USB and Ethernet Interface

14-1. USB Interface Specifications

1. General Specification: Conforms to USB 2.0 Specifications
2. Communication Speed: USB Full Speed Mode (12 Mbps)
3. Communication Method: USB Bulk Transmission Mode
4. Power Specifications: USB Self-power Function
5. Connector: USB Up-Stream Port Connector (USB Type-B)

14-2. Ethernet Interface Specifications

1. General Specification: Conforms to IEEE802.3
2. Communication Media: 10 Base-T/100 Base-TX
3. Communication Speed: 10/100 Mbps
4. Protocol: TCP/IP
5. TCP/IP detail: ARP, RARP, BOOTP, DHCP, LPR, #9100
HTTP, TELNET, FTP
6. Connector: RJ-45 (8-pin modular)

Note: Factory-set login password for administrator

One of the following protocols may be used for changing the settings on this product: HTTP (web), TELNET, or FTP. To do so, it is necessary to log in using an administrator account for the product.

Use the following administrator account information on HTTP (web), TELNET, or FTP.

Administrator account name: “root” (required)

Password: “public” (required)

The password may be changed after logging in.

15. Peripheral Unit Drive Circuit

Peripheral unit drive circuit connector only connects to peripheral units such as cash drawers, etc.

Do not connect it to a telephone.

Use cables which meet the following specifications.

Peripheral Drive Connector

Pin No.	Signal name	Function	I/O direction
1	FG	Frame ground	—
2	DRD1	Drive signal 1	OUT
3	+24 V	Drive power	OUT
4	+24 V	Drive power	OUT
5	DRD2	Drive signal 2	OUT
6	DRSNS	Sense signal	IN

Modular plug

Modular plug: MOLEX 90075-0007, AMP641337, or BURNDY B-66-4

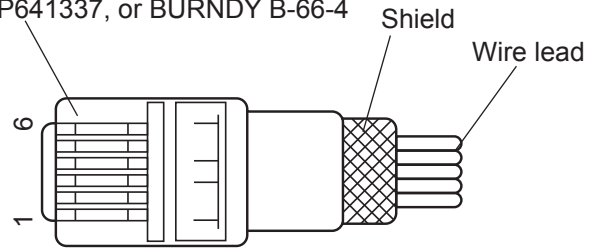

Drive circuit

The recommended drive unit is shown below.

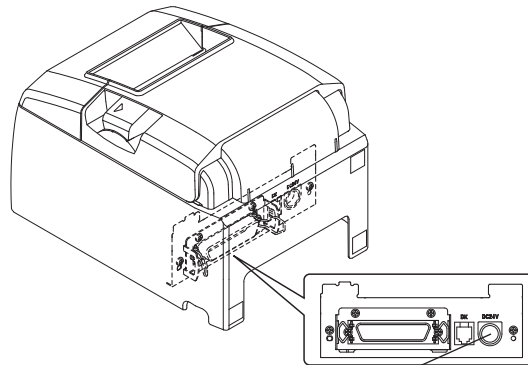

Peripheral drive connector

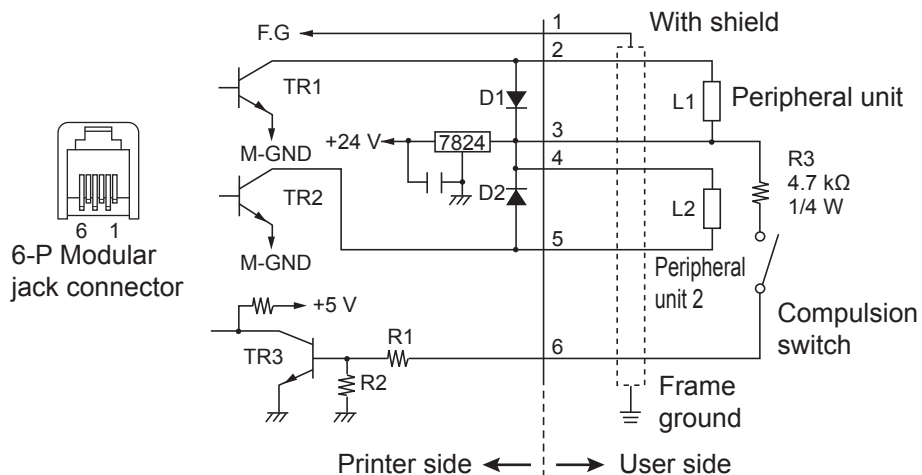

Reference
2SD 1866 Circuit Configuration

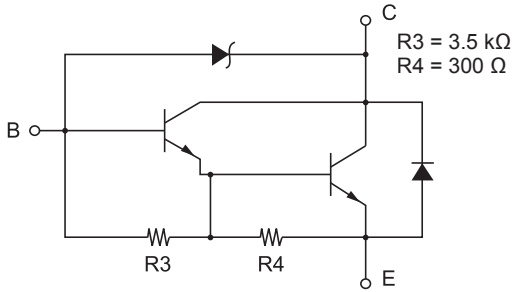

Drive Output: 24 V, Max. 1.0 A
 TR1, TR2: Transistor 2SD 1866 or equivalent
 R1=10 kΩ
 R2=33 kΩ

- Notes:**
- Peripheral units 1 and 2 cannot be driven simultaneously. To drive them continuously, set the duty cycle ratio to 20% or less (excluding an externally connected buzzer).
 - The following external buzzer is available as an option.
 External buzzer model: RMB-24
 Voltage rating: 24V
 Average consumption current: Max. 21 mA (at 24V)
 Sound pressure: Min. 75 dB at 1 m
 Lead wires: red (+) black (-)
 - Never use the external buzzer command if you connect a device (such as a cash drawer) other than an external buzzer. It could damage the connected device and the printer circuit. Refer to the separate Programmer's Manual for details on commands.
 - The status of the compulsion switch can be known from the status command. Refer to the separate Programmer's Manual for details.
 - Minimum resistance for coils L1 and L2 is 24.
 - Absolute maximum ratings for diodes D1 and D2 ($T_a = 25^\circ\text{C}$) are:
 Average Rectified Current $I_o = 1\text{A}$
 - Absolute maximum rating for transistors TR1 and TR2 ($T_a = 25^\circ\text{C}$) are:
 Collector current $I_c = 2.0\text{ A}$

16. Memory Switch Settings

Each memory switch is stored in EEPROM. For details on the functions and settings of memory switches, please consult the dealer.

The table below shows the factory settings for the memory switches.

Memory Switch	Hexadecimal Code
0	0000
1	0000
2	0000
3	0000
4	0000
5	0000
6	0000
7	0000
8	0000
9	0000

⚠ WARNING

Changing the memory switch settings can cause the printer to fail to operate correctly.

17. Release History

Rev. No.	Date (Month/Day/ Year)	Contents
Rev.1.0	09/30/2007	New Release
Rev.1.2	07/30/2010	Page 6: Added the description about the Ethernet interface board IFBD-HE07.
Rev.1.21	09/30/2010	Page 8: Added the description about Windows 7.
Rev.1.22	09/22/2011	



URL: <http://www.starmicronics.com/support/>